

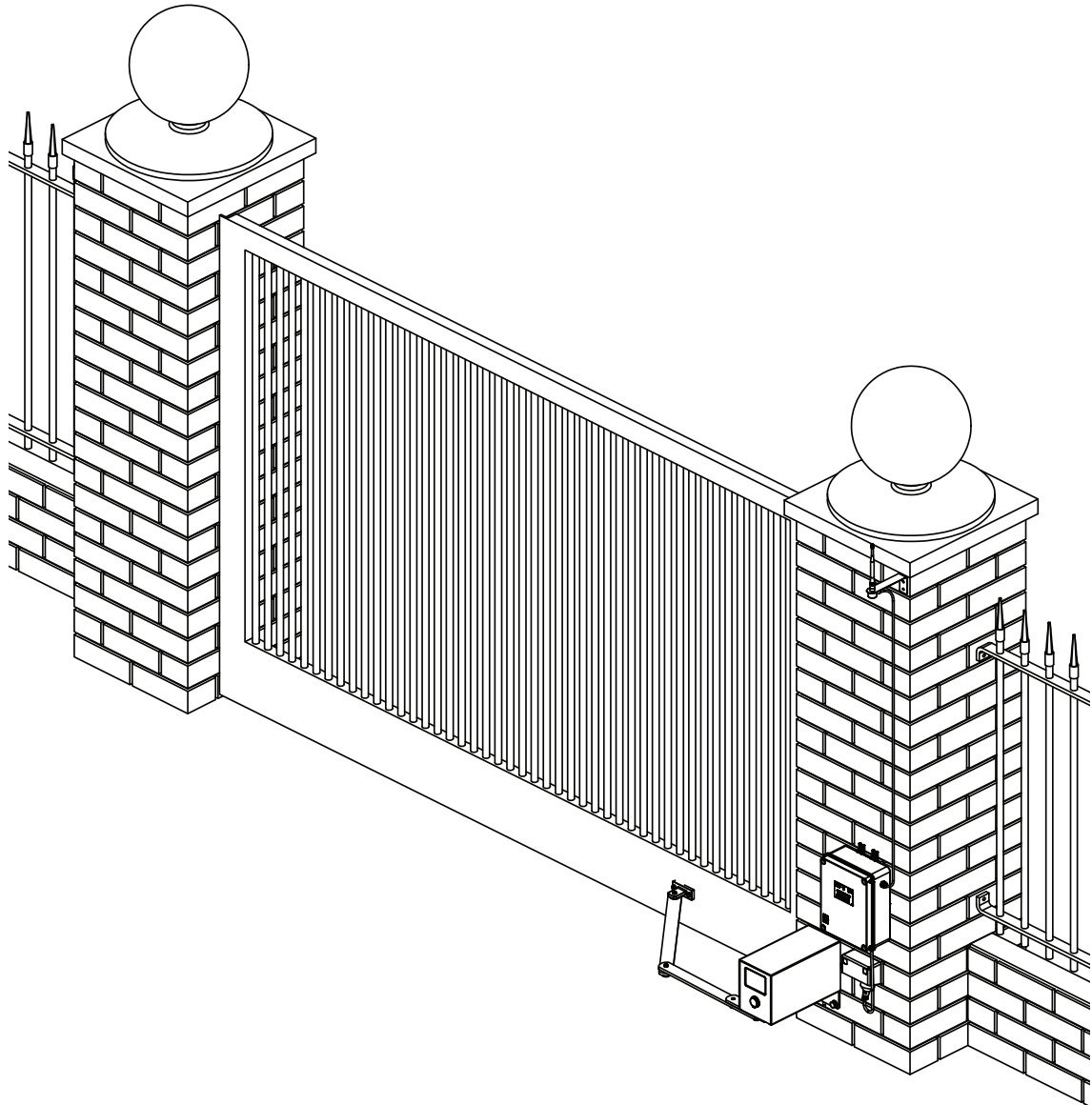

Elite®

Swing Gate Opener



automatic
TECHNOLOGY

smart | simple | secure



WARNING: It is vital for the safety of persons to follow all instructions. Failure to comply with the installation instructions and the safety warnings may result in serious personal injury and/or property and remote control opener damage. Please save these instructions for future reference.

Automatic Technology Australia Pty Ltd to the extent that such may be lawfully excluded hereby expressly disclaims all conditions or warranties, statutory or otherwise which may be implied by laws as conditions or warranties of purchase of an Automatic Technology Australia Pty Ltd Elite® Swing Gate Opener. Automatic Technology Australia Pty Ltd hereby further expressly excludes all or any liability for any injury, damage, cost, expense or claim whatsoever suffered by any person as a result whether directly or indirectly from failure to install the Automatic Technology Australia Swing Gate Opener in accordance with these installation instructions.



Elite®

Swing Gate Opener

Important Safety Instructions	4		
Features	6		
Kit Contents	8		
Drive Unit Installation	9		
Installing Drive Unit Arms	11		
Installing Minimum Sideroom Kit	12		
Mounting Control Box	12		
Electrical Connection Single Leaf	14		
Electrical Connection Dual Leaf	15		
DCB-05 Board Layout	16		
Menu Structure	18		
Setting Travel Limits	19		
Coding Transmitters	21		
Standard Operating Modes	22		
Control Board Adjustments	23		
Menu 2 Current Trips	23		
Menu 3 Auto-Close Times	24		
Menu 4 Lock Times	25		
Menu 5 Light Times	25		
Menu 6 Motor Settings	25		
Menu 7 Operating Modes	26		
Diagnostic Tools	28		
Menu 8.1 Test Inputs	28		
Menu 8.2 Test Tx'ers	28	Setting Pedestrian Position	30
Menu 8.3 Display History	28	Accessories Installation	31
Menu 8.4 Memory Usage	28	Battery Backup Installation	33
Menu 8.5 Service Counter	29	Troubleshooting Guide	34
Menu 8.6 Counters	29	Specifications	35
Memory Tools	30	Spare Parts List	36
Menu 9.1 Clr Control	30	Notes And Record	37
Menu 9.2 Clr Tx'ers	30	Warranty	38





Important Safety Instructions

WARNING: It is vital for the safety of persons to follow all instructions. Failure to comply with the following Safety Instructions may result in serious personal injury and/or property damage.



FOR ADDITIONAL SAFETY protection we strongly recommend the fitting of a Photo Electric (PE) Beam. In most countries, PE Beams are mandatory on all gates fitted with automatic openers. For a small additional outlay, Automatic Technology recommends that Photo Electric Beams be installed with the automatic opener ensuring additional safety and peace of mind.

DO NOT operate the gate opener unless the gate is in full view and free from objects such as cars and children/people. Make sure that the gate has finished moving before entering or leaving the driveway.

DO NOT operate the gate opener when children/people are near the gate. Children must be supervised near the gate at all times when the gate opener is in use. **Serious personal injury** and/or property damage can result from failure to follow this warning.

DO NOT allow children to operate the swing gate opener. **Serious personal injury** and/or property damage can result from failure to follow this warning.

Make sure that the **Safety Obstruction Force** system is working correctly, and is **tested** every month. Test as per the Installation Instructions Manual. Adjust if necessary and recheck. Failure to follow this rule could result in **serious personal injury** and/or property damage. This test must be repeated at regular intervals and the necessary adjustments made as required.

DO NOT disengage the swing gate opener to manual operation with children/people or any other objects including motor vehicles within the gateway.

If using a key switch, keypad or any device that can operate the swing gate opener, make sure it is out of reach of children and that the gateway is in full view at all times.

If the power supply cord is damaged, it **must** be replaced by an Automatic Technology service agent or suitably qualified person.

Make sure that remote transmitters are kept out of reach of children.



Important Safety Instructions

Please read this instruction manual fully before attempting to install or use the opener. Failure to comply with the installation instructions may result in serious injury and/or property damage.

The Elite® swing gate opener should not be immersed in water or sprayed directly by a hose or other water carrying device.

The gate(s) must be **well balanced** and in good working order. Faulty gates must be repaired by a qualified technician prior to opener installation.

Remove or disengage all gate locks and mechanisms prior to installation of the opener.

Connect the gate opener to a properly **earthed** general purpose 240V mains power outlet installed by a qualified electrical contractor.

Disconnect the power cord from mains power before making any repairs or removing covers. Only **experienced** service personnel should remove covers from the gate opener.

Keep hands and loose clothing **clear** of the gate and opener at all times.

When using Auto-Close mode, a **Photo Electric Beam** must be fitted correctly and tested for operation at regular intervals. **Extreme caution** is recommended when using Auto-Close mode. **All safety instructions** above must be followed.

In order for the gate opener to **sense** an object obstructing the gateway, some **force** must be exerted on the object. As a result the object, gate and/or person may suffer **damage** or **injury**.

Make sure that the gate is fully open before driving into or out of the driveway. Make sure the gate is fully closed before leaving the driveway.

The gate opener is not intended for use by young children or infirm persons without adequate supervision. Children should be supervised to ensure that they do not play with the remote transmitters or the opener.

Frequently examine the installation and mountings for signs of wear, damage or imbalance. **DO NOT** use if repair or adjustment is needed since a fault in the installation or an incorrectly balanced gate may cause injury.





Features

Thank you for purchasing the Elite® Swing Gate Opener from Automatic Technology. Designed for residential hinged swing gates by our world renowned team of engineers, this unit will give years of smart, simple and secure operation. Listed below are some of its many features.

Dual Leaf Gate

A dual leaf gate can be controlled with the addition of a second drive unit. Mains power is only required for the control box and a 5-core low voltage cable for the drive units.

Operation

To activate the gate simply press a button on the TrioCode® transmitter, keypad or other optional control devices. During an open or close cycle, the gate can be stopped by pressing the button whilst it is in motion. The next actuation will move the gate in the opposite direction.

Operator Console

The DCB-05 gate controller features a LCD display operator console which simplifies installation, adjustments and status indication. Features include editing transmitter storage and names, setting parameters, selecting specialised operating modes and performing system diagnostics.

TrioCode™ Code Hopping Technology

Every time a TrioCode™ transmitter is used, a new security code is randomly generated from over 4.29 billion possibilities. This greatly enhances the security of the system and makes “code grabbing” a thing of the past.

These transmitters also overcome interference issues by simultaneously sending a signal over three different frequencies. Even if two of the three signals are jammed, the system will still work.

Security Code Store

The Elite® Swing Gate Opener uses revolutionary technology to securely store up to five hundred and eleven (511) transmitters in its memory with the ability to assign an 11 character name to each.

Installation

The display console on the DCB-05 gate controller “holds your hand” through the installation and setup process. Also, during installation a handheld transmitter can be used to set gate travel limits, allowing the installer to closely monitor the gate’s position and stop points instead of having to be within arms reach of the console.

Gate Sync Delay

If the gate leaves overlap, a delay can be used to start one leaf moving without interfering with the other.





ISS (Intelligent Safety System)

Should the gate hit an obstacle or be restricted in some manner, it will automatically reverse. The amount of force the gate should encounter before reversing is automatically adjusted by the control system during the initialisation of the automatic opener. The gate will also stop if restricted whilst opening. The Safety Obstruction Force should be checked at least once a month. See installation manual for instructions.

Status Indicator

The LCD console display screen indicates through text the status of the Elite® Swing Gate Opener. When the MAIN SCREEN is displayed, the current position of the gate or the result of the last movement can be viewed. The display also shows the countdown timer for Auto-Close operations. Any active input will also be displayed along with the state of various features such as periodic service, battery backup operation and vacation mode.

Control of Lock and Lights

The incorporated controller has dedicated outputs for operating an electric lock, warning or courtesy lights. The timing of these outputs can be adjusted to suit your needs. In addition, a button on a remote transmitter can be coded to operate the light output.

Extensive Operating Modes Via Control Inputs

The DCB-05 gate controller can be configured to operate in many different ways via the seven (7) control and safety inputs which include P.E, AUXILIARY OPEN, STOP, CLOSE, OSC, SWIPE and PEDESTRIAN.

Operating Modes Via Remote Controls

Operation is provided with each transmitter's button being able to be configured to operate one of OSC, PEDESTRIAN, SWIPE, CLOSE, OPEN, STOP, LIGHT or VACATION functions.

The functionality of the transmitter is further enhanced by four (4) Auto-Close modes, three (3) PE Beam response modes and two (2) pedestrian response modes.

SmartSolar™ and Battery Backup Compatibility (optional)

The Elite® swing gate opener can be fitted with a SmartSolar™ or Battery Backup kit for operation in the event of a power outage, or where mains power access is not available.

Pedestrian Mode

The gate can be programmed to open partially to allow pedestrian access. In a dual leaf gate, only one leaf opens to allow pedestrians through without permitting vehicle access.

Manual Operation

The opener can be disengaged and the gate operated manually by opening the drive unit cover and disengaging the gearbox. If power to the opener is disrupted for any reason, it can be disengaged. This will allow you to manually open or close the gate.





Kit Contents

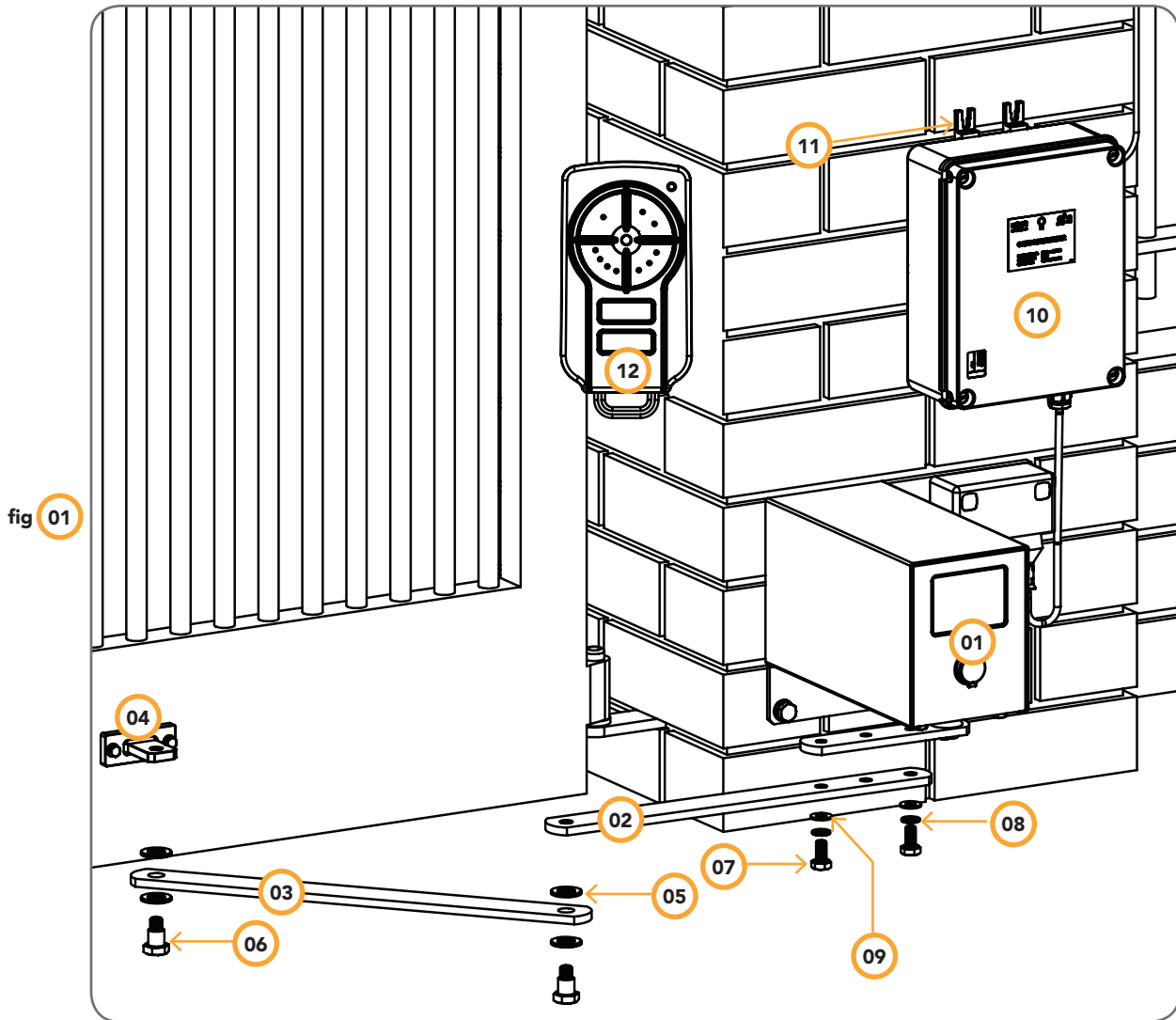

ITEM	DESCRIPTION	QTY
1.	Drive Unit	1
2.	Drive Arm Extension	1
3.	Slave Arm	1
4.	Gate Mounting Bracket	1
5.	Plastic Washer	4
6.	Shoulder Screw	2
7.	Hex Head Screw	2
8.	Spring Washer	2
9.	Flat Washer	2
10.	Control Box	1
11.	Control Box Mounting Bracket	4
12.	PTX-5 Keyring Transmitter	2





Drive Unit Installation

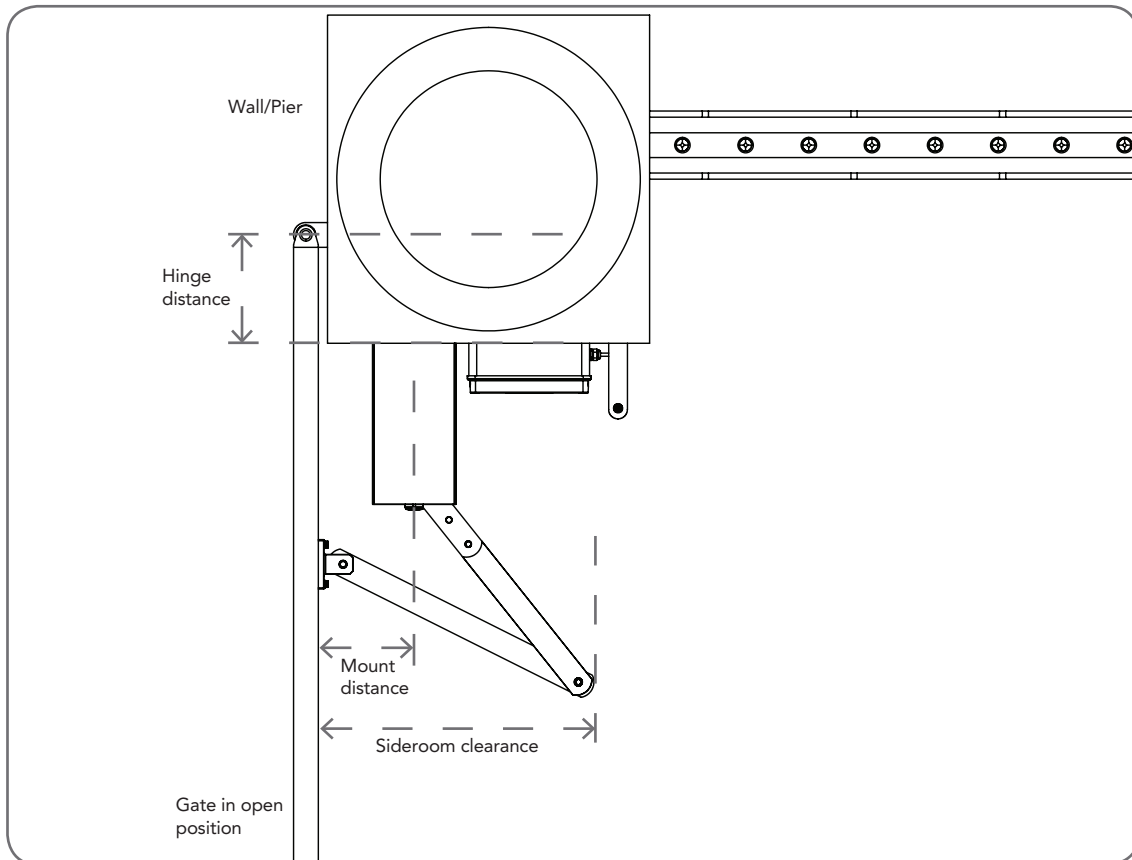

fig 02

Mounting The Drive Unit

The Elite® swing gate opener is designed to operate most residential swing gates. The gates must be in good working condition and should operate by hand relatively freely. Wind loading may affect the operation of the opener in high wind areas. Correct obstruction and reversing settings should be chosen for trouble free operation.

Pre-installation Inspection

Before commencing installation, check the following:

1. The gate moves freely by hand for the full length of open and close travel.
2. The pier or post for mounting must be of solid construction (Brick, solid timber or steel). It must bear most of the force applied by the drive unit.
3. A weatherproof 240V 10A general purpose power point should be available within one metre of the pier/post. If Elite® gate openers are required, provision for underground cabling should be made from one post to the other.
4. Ensure sideroom clearance is adequate. Refer to Table on page 10. If there is not enough sideroom available, the Minimum Sideroom Kit (Page 12) is required.
5. The mount distance of the Drive Unit should be recorded. This value will be used later.





Drive Unit Installation

Mount Distance	Hinge Distance								
	0	50	100	125	150	180	200	220	mm
	Sideroom clearance								
fig 03 90	470	470	470	470	470	470	465	460	mm
120	450	470	480	470	465	460	435	425	mm
140	470	465	470	465	460	440	420	390	mm
200	470	465	445	430	400	350	390	250	mm

fig 03

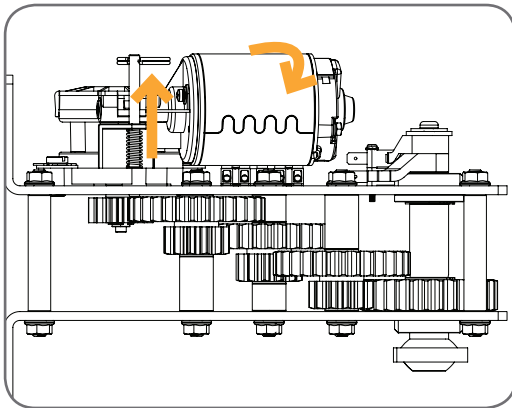

fig 04

The mount distance for the drive unit and the hinge distance for the gate can be selected to optimise the sideroom clearance. See **Fig. 03**.

NOTE: If the gate is already installed, measure the hinge distance and use this table to optimise the mount distance.

1. Mount drive unit using four (4) 10mm loxins or dynabolts.
2. Make sure that the Drive Unit is mounted at an appropriate height from the ground - allow minimum 35mm clearance for drive arm extension.

NOTE: If the gateway slopes away from pier/post, make sure an allowance is made for clearance of the drive arm extension and slave arm to not touch the ground.

fig 05

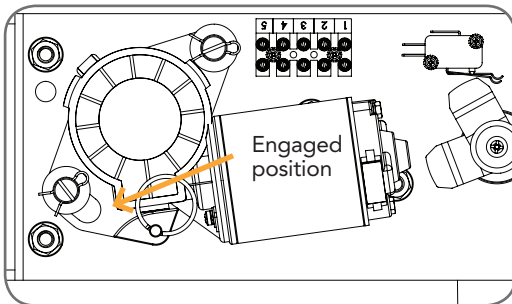

Manual Operation

Disengage drive motor by pulling manual release pin up using the release ring. While holding the ring, rotate the motor assembly clockwise. (**Fig. 04, 05 & 06**)

To re-engage, pull pin and rotate motor assembly anti-clockwise until manual release pin clicks into place.

fig 06

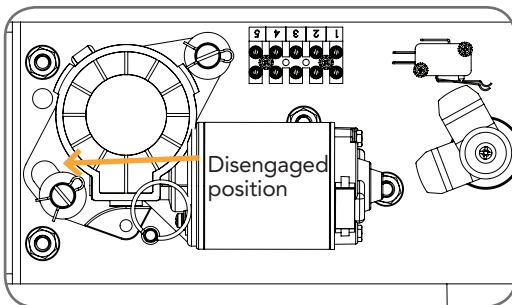



Installing Drive Unit Arms

fig 07

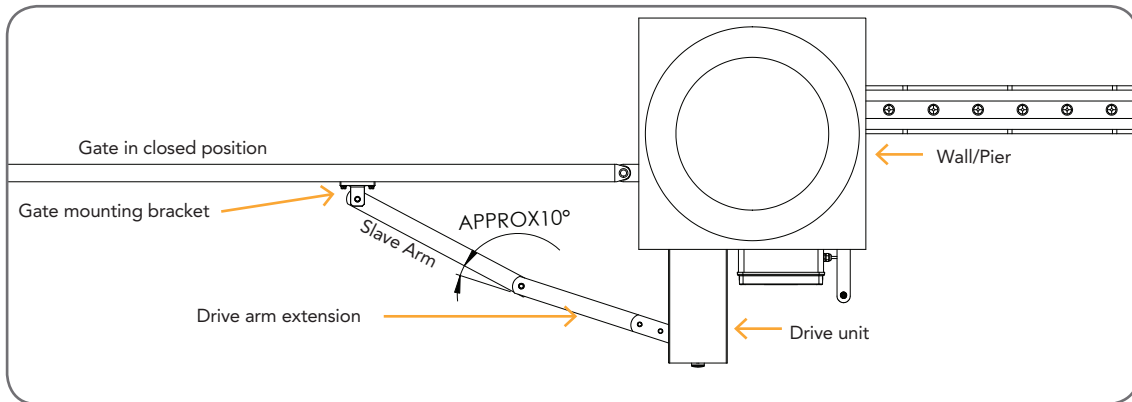

Affixing Arms And Brackets To Gate

1. Position gate in close position.
2. Attach drive arm extension to drive arm (fixed to the drive unit) (**Fig. 01**), using two (2) Hex Head screws, spring and flat washers supplied.
3. Attach slave arm to drive arm extension using plastic washers and shoulder screw supplied. (See Page 8).
4. Assemble Gate Mounting Bracket and Slave Arm using shoulder screw and plastic washers. Do not tighten yet.
5. Extend arms out straight and mark position where the Gate Mounting Bracket touches the gate (**Fig. 07**). From this mark, measure 10mm toward Drive Unit and mark again. This is where the Gate Mounting Bracket will be mounted.
6. Remove the Gate Mounting Bracket from the Slave Arm and secure the Gate Mounting Bracket to the gate at second mark.
7. Reassemble Slave Arm to Gate Mounting Bracket using shoulder screw and plastic washers. Secure firmly.





Installing Minimum Sideroom Kit

fig 08

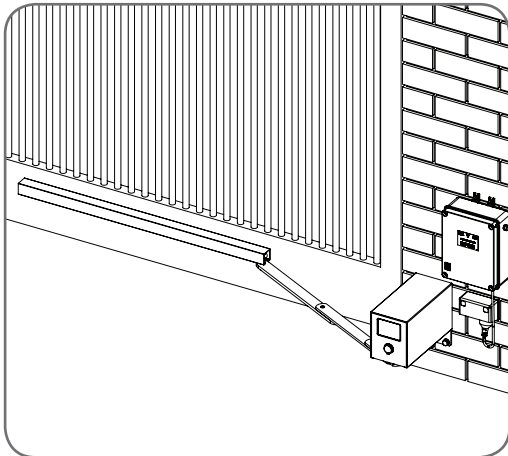

Minimum Sideroom Kit

If you have limited sideroom, an optional minimum sideroom kit reduces the gate opener's required sideroom to the width of the drive unit (135mm). (ATA Order code 90182).

Fitting Minimum Sideroom Kit

1. Secure the extension arm from the Minimum Sideroom Kit onto drive arm extension with supplied M12 screws.
2. Drill $\text{\O}12$ hole in the Drive Arm Extension (use hole in extension arm as a guide).
3. Insert the other M12 screw and secure with spring washer and nut. Check that the screws are tight (**Fig. 09**)
4. Check that the Drive Unit is disengaged and the gate is closed. Slide the Guide Track over the idler. Locate Track on the gate and check travel of the Arm. The idler should always be inside the Guide Track in the closed and open positions (**Fig. 08**).
5. Secure the track to the gate (weld if possible).

NOTE: If a shorter arm is required, drill the drive arm extension and extension arm where appropriate. You should not have to cut the arms and you should still be able to use pre-threaded hole in the drive arm extension.

fig 09

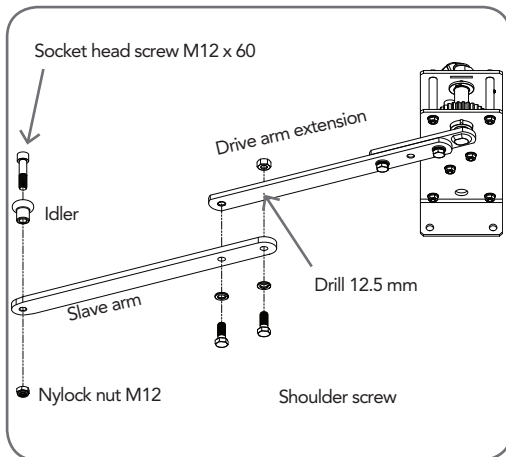

Mounting Control Box

fig 10

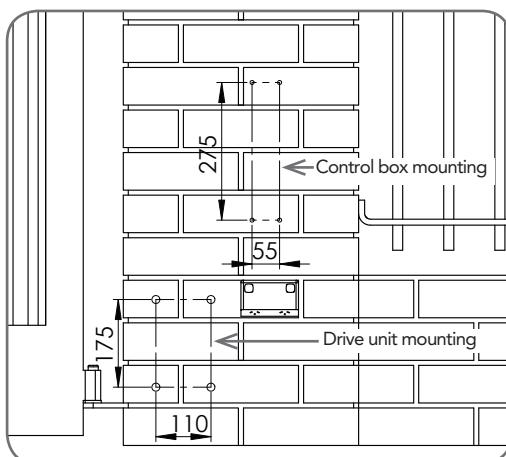

Mounting Control Box

CAUTION: do not use any cables which carry green/yellow wires as this signifies earth, and do not comply with electrical authority regulations.

1. The control box should be mounted near the drive unit using four (4) 6mm screws.
2. Drill holes as per (**Fig. 10**). When locating the control box, allow ample space around the unit for easy access and wiring connections.
3. Remove cover from control box.
4. Determine which leaf you would like to open first and close last. This gate leaf must be connected to Motor 1 (M1) terminals on the control board.
5. Connect drive unit(s) to control board using 5-core cable. For detailed electrical connection see (**Fig. 14, 15, 16 & 17**).



Mounting Control Box



Note: To determine left or right hand installation, stand inside the driveway looking out to the street.

Antenna

Mount the antenna at or above the height of the gate or fence for optimal reception, which ever is higher. (Fig. 11). Do not cut antenna or coaxial cable.

Cams Setup

Setting of limits for open and closed position is performed with opener in the manual position.



WARNING: do not switch power on or engage motor drive.

For Right Hand Side Installation:

When gate is closed, turn lower cam in a clockwise direction (Fig. 12 & 13) until an audible click can be heard from the lower micro-switch. Open the gate to the required opening position and turn top cam in an anticlockwise direction until a click can be heard from top micro-switch.

For Left Hand Side Installation:

When gate is closed turn lower cam in a anticlockwise direction (Fig. 12 & 13) until an audible click can be heard from the lower micro-switch. Open the gate to the required opening position and turn top cam in a clockwise direction until a click can be heard from lower micro-switch.

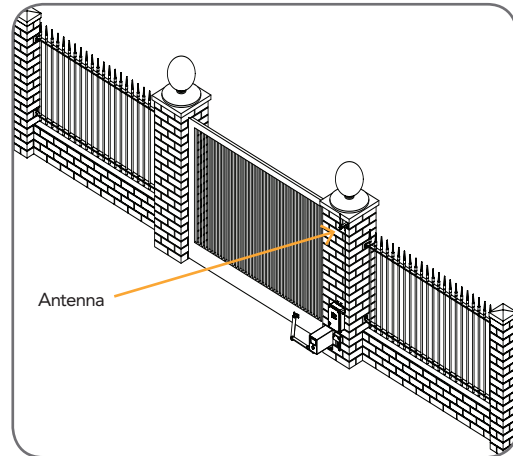

fig 11

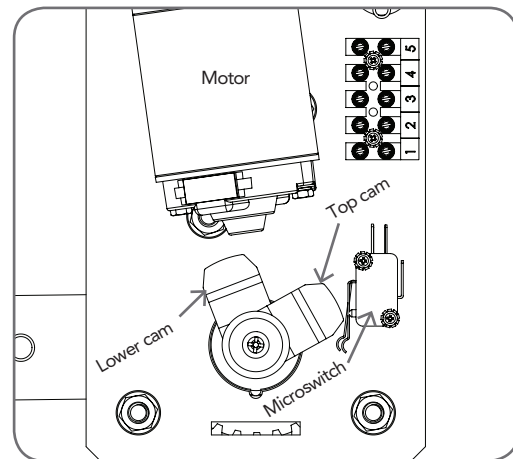

fig 12

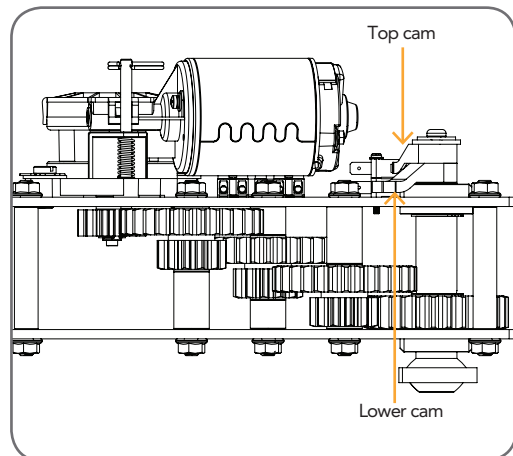

fig 13





Electrical Connection - Single Leaf

fig 14

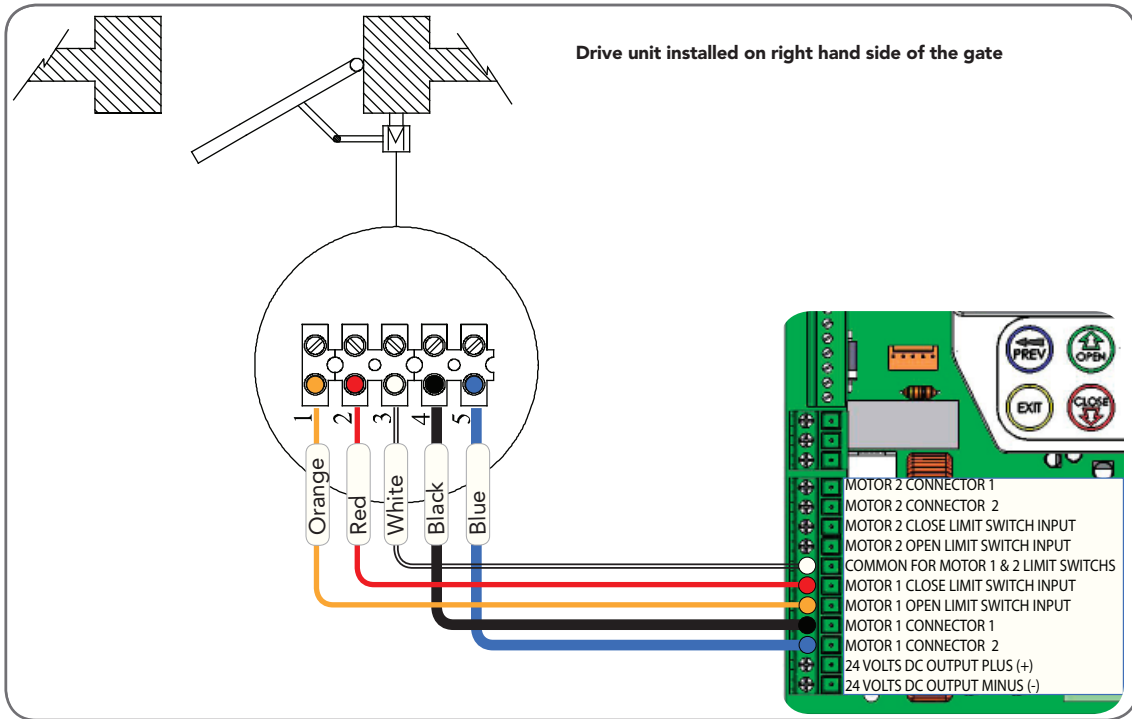
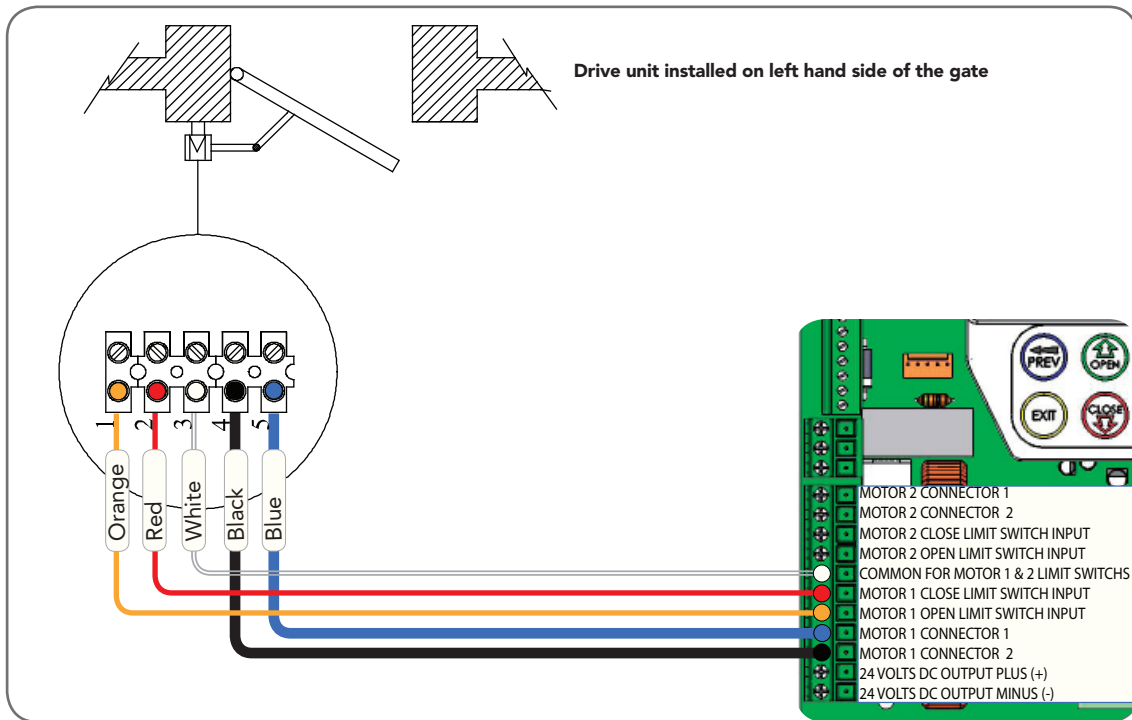

fig 15





Electrical Connection - Dual Leaf

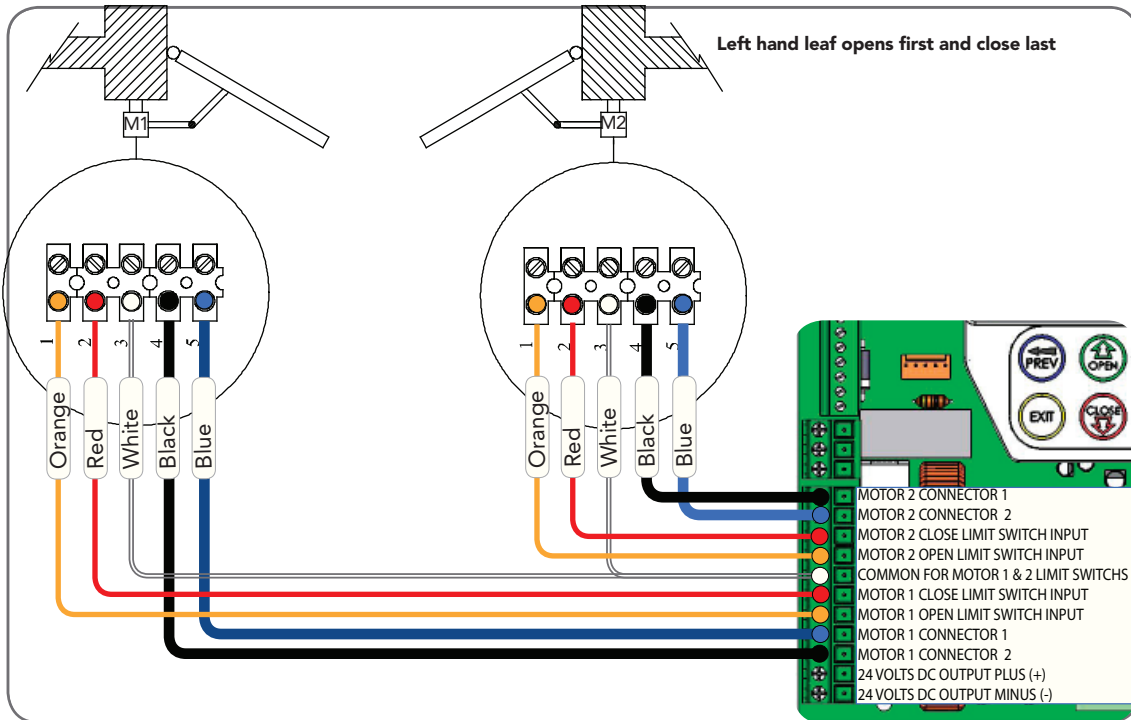

fig 16

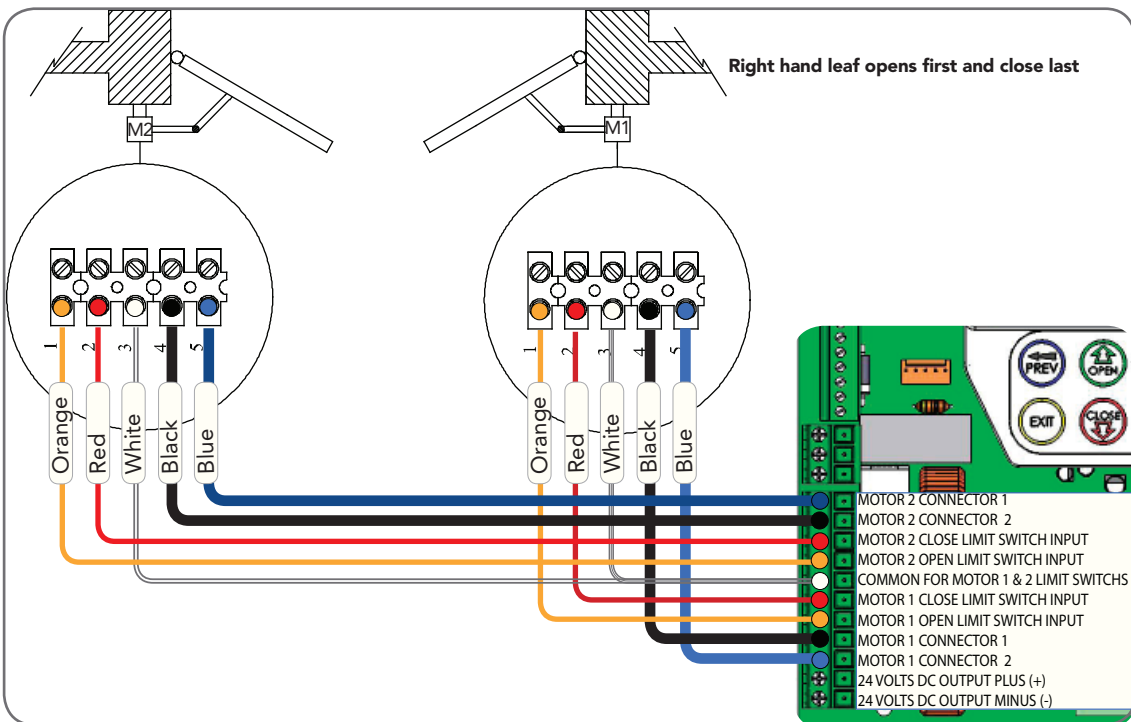

fig 17





Control Board Layout

- 01 PE V+ is used to power photo electric beam.
- 02 PE In for photo electric beam for safety
- 03 PE (v-) is used to supply (-) volt to photo electric beam.
- 04 Aux control input
- 05 OPN Programmable N/O or N/C input terminal
- 06 STP Programmable N/O or N/C input terminal
- 07 CLS N/O input terminal
- 08 OSC N/O input terminal
- 09 SWP N/O input terminal
- 10 PED N/O input terminal
- 11 COM terminal for input terminals 1 to 8
- 12 OUTPUT 2 (optional relay module coil drive)
- 13 OUTPUT 2 (optional relay module coil drive)
- 14 OUTPUT 1 N/C relay contact
- 15 OUTPUT 1 COM relay contact
- 16 OUTPUT 1 N/O relay contact
- 17 MOTOR 2 terminal 1
- 18 MOTOR 2 terminal 2
- 19 MOTOR 2 close limit switch input terminal
- 20 MOTOR 2 open limit switch input terminal
- 21 COM terminal for Terminals 16,17,19 & 20.
- 22 MOTOR 1 close limit switch input terminal
- 23 MOTOR 1 open limit switch input terminal
- 24 MOTOR 1 terminal 1
- 25 MOTOR 1 terminal 2
- 26 24VDC (+) output for powering accessories
- 27 24VDC (-) output for powering accessories
- 28 Standby battery / solar charger connector
- 29 24VAC power input (from transformer)
- 30 10 amp fuse
- 31 Programmer Input
- 32 Console keypad
- 33 Console display (LCD)
- 34 Antenna connector





Control Board Layout

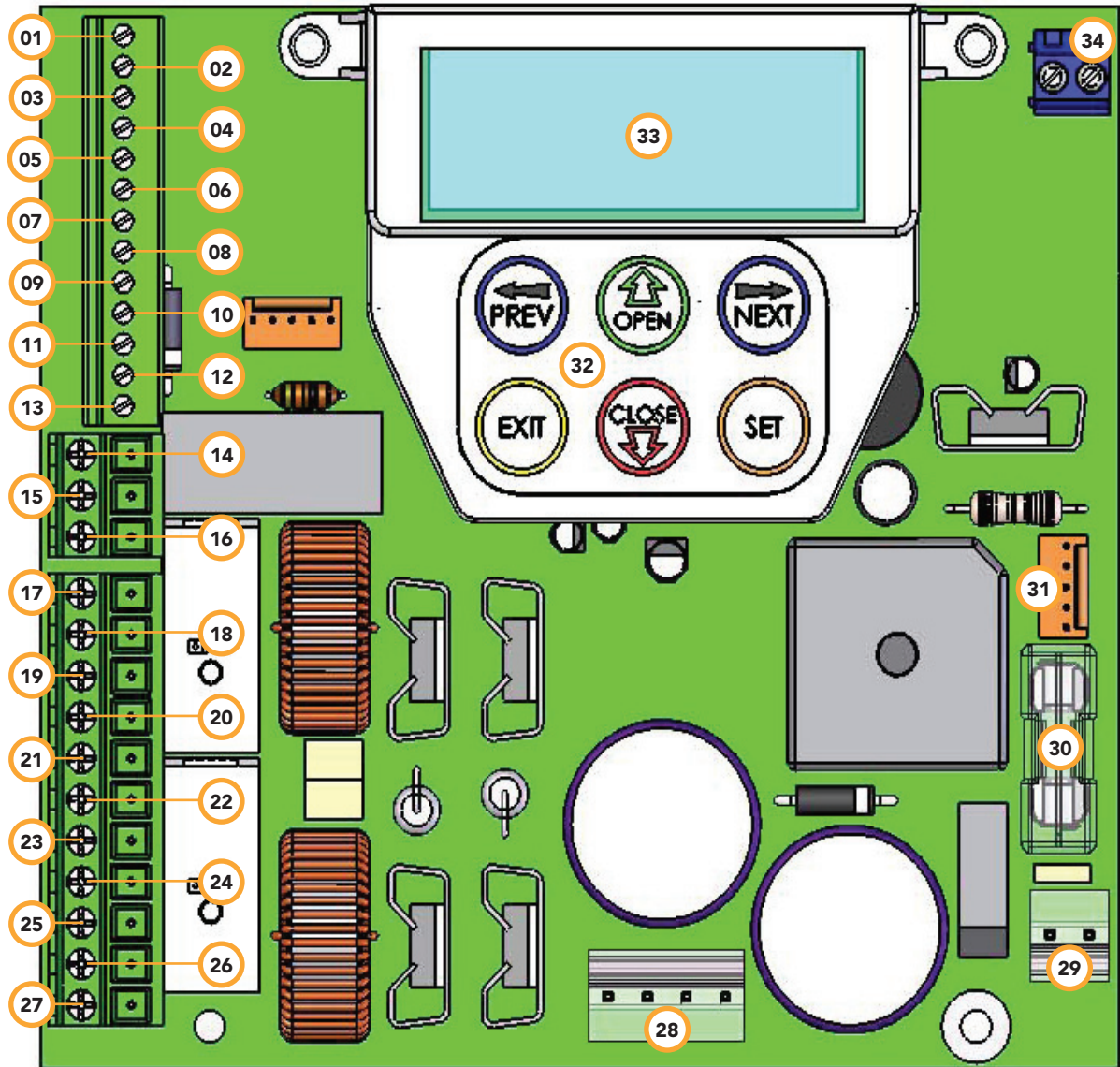
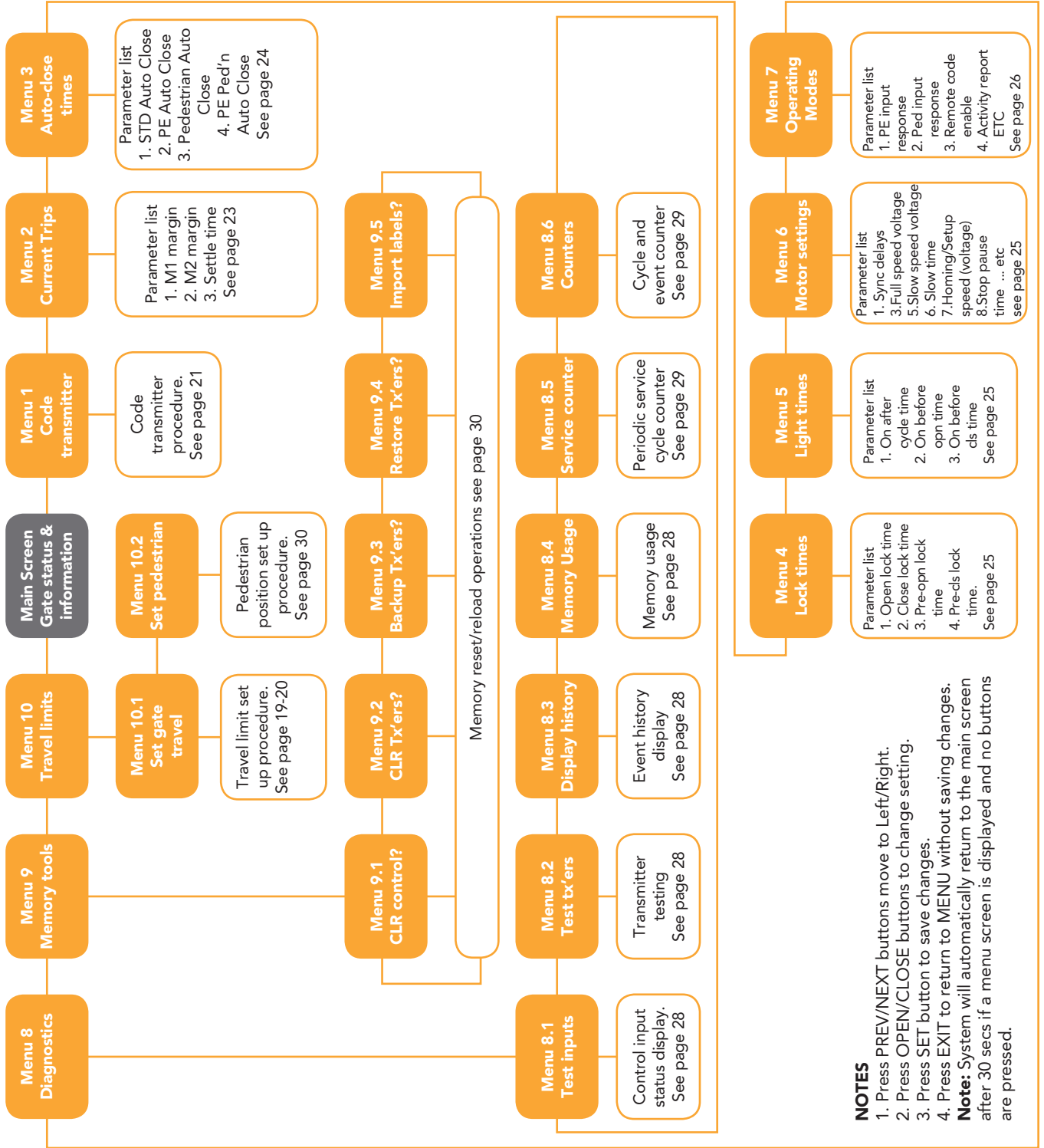

fig 18





Menu Structure



NOTES

1. Press PREV/NEXT buttons move to Left/Right.
2. Press OPEN/CLOSE buttons to change setting.
3. Press SET button to save changes.
4. Press EXIT to return to MENU without saving changes.
Note: System will automatically return to the main screen after 30 secs if a menu screen is displayed and no buttons are pressed.





Setting Travel Limits

PLEASE NOTE - Before plugging the gate control system in, check the power cord for damage and ensure it cannot become entangled in any moving parts



WARNING: make sure the obstruction sensitivity is adjusted correctly on installation so that the gate(s) reverse to the open position when obstructed with minimum pressure and stops on opening cycle when obstructed with minimum pressure. Failure to comply with the set up procedure may result in serious personal injury and/or property damage.

1. Connect the five core cable from the control box to the drive unit(s).
2. Fully open the gate and engage the motor assembly.
3. After checking the initial wiring, apply power to the DCB-05. The controller will go through a startup sequence displaying the STARTUP SCREEN which indicates the controller type and firmware version **Fig. 19**.

After a short delay the MAIN SCREEN will be displayed. If this is the first time the DCB-05 has been used, the MAIN SCREEN should indicate that the limits are not set **Fig. 20**.

If the display shows that some input is active, rectify the situation before proceeding. If a default setting is to be changed, it should be done now before setting the travel limits.

Step 1. Navigating To "Limit/Amp Travel Menu"

To navigate to Menu 10.1 from the main screen, simply scroll to the left using the PREV button to access MENU 10, followed by SET to display MENU 10.1 (**Fig. 21**). Press SET again to start the limit setting procedure.

Step 2. Confirming Ready To Start

DCB-05 will prompt you to confirm that the motor wiring is complete (**Fig. 22**) and that the gate(s) are in a fully open position and engaged. Press SET to confirm (**Fig. 23**).

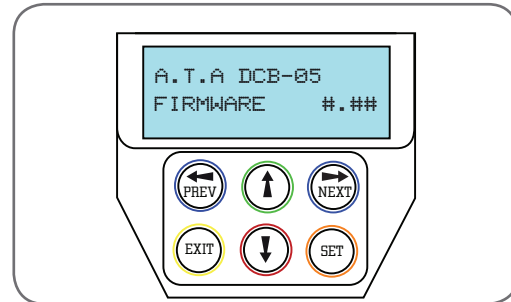

fig 19

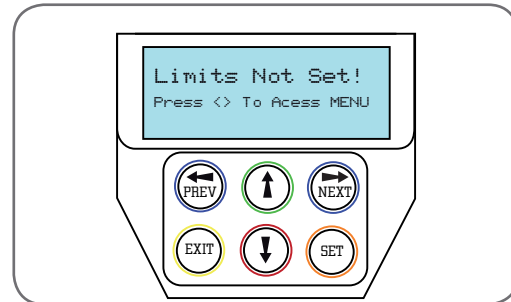

fig 20

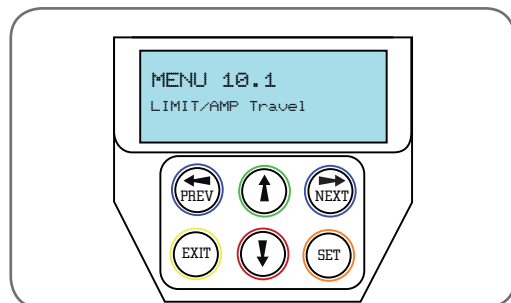

fig 21

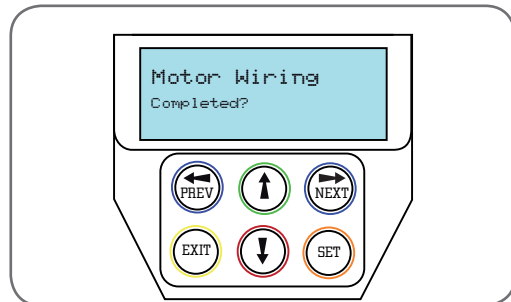

fig 22

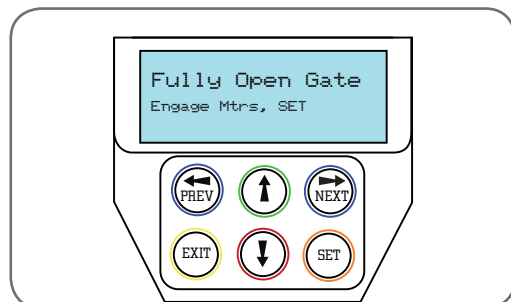

fig 23





Setting Travel Limits (Cont.)

fig 24

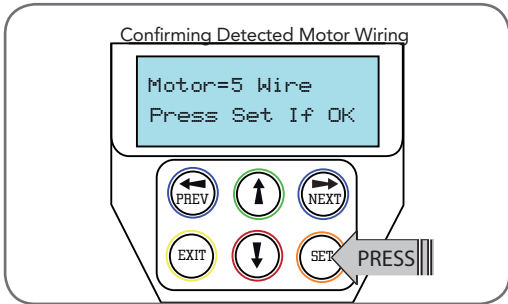

Step 3. Confirming Correct Wiring Detected

DCB-05 will now automatically detect the type of drive unit used by the number of wires used. If the correct number of wires is displayed (**Fig. 24**) then press SET to continue. Otherwise press EXIT and check the wiring.

fig 25

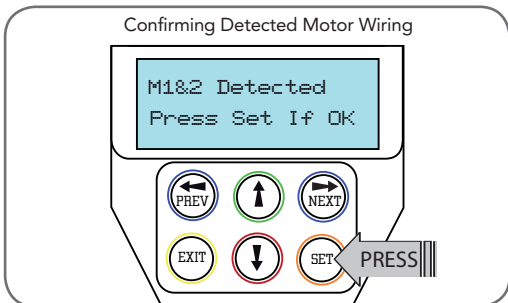

Step 4. Confirming Motors Detected

DCB-05 will now automatically detect if one or two motor are connected. If the correct number is displayed, then press SET to confirm. Otherwise press EXIT and check the wiring (**Fig. 25**).

fig 26

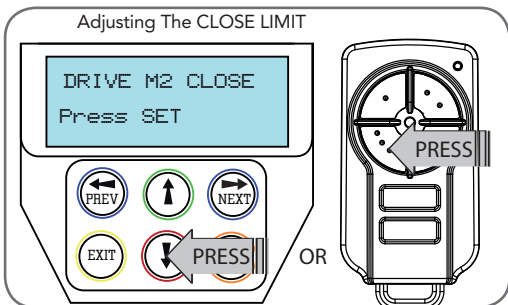

Step 5. Adjusting Close Limit(s)

DCB-05 will now prompt one at a time for the motor(s) to be driven to the desired close limit and for the limit switches to be adjusted so that the motor stops at the desired position (**Fig. 26**).

The motor can be driven using the UP and DOWN buttons on the console keypad or Button 1 and 4 of a transmitter. In the limits setup mode, the display will show the percentage of the power used to move the gate (**Fig. 27**).

After making adjustments to the limit switch positions always re-approach the limit at full speed by driving the motor open a short distance and then driving it close again. When the close limit has been adjusted, press SET to continue.

Note: If the motor drives in the wrong direction (UP closes gate / DOWN opens gate), the motor wires need to be swapped.

fig 27

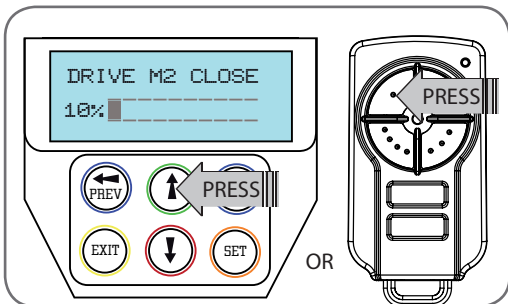

Step 6. Adjusting Open Limit(s)

DCB-05 will now prompt for the motor(s) to be driven to the desired open limit and for the limit switches to be adjusted so that the motor stops at the desired position.

The motor can be driven using the UP and DOWN buttons on the console keypad or Button 1 and 4 of a transmitter. In the limits setup mode, the display will show the percentage of the power used to move the gate.

After making adjustments to the limit switch positions always re-approach the limit at full speed by driving the motor close a short distance and then driving it open again. When the open limit has been adjusted, press SET.

Step 7. Automatic Profiling

After a brief pause, DCB-05 will automatically close and open gate several times and learn the gates load and travel characteristics. When the setup is complete, the MAIN SCREEN will be displayed "Gate is closed". The gate can now be used.





Coding Transmitters

DCB-05 can store up to five hundred and eleven (511) transmitters in its memory. Each transmitter can be allocated an alpha-numeric ID label up to eleven (11) characters in length. Each button can be assigned to one of several control functions.

The settings for a transmitter are represented in **Fig. 28**. It shows the transmitter's store number, ID label or serial number and the functions assigned to each of its four buttons.

To toggle between ID/SN display, press UP/DOWN with the cursor on the ID/SN indicator.

BRAND OF TRANSMITTERS

First memory location sets the type of transmitters which can be stored into the memory of the receiver. It either can be ATA TrioCode™ or B&D Tri-Tran™ transmitters.

For example, if the first transmitter stored is TrioCode™ then rest of transmitters can only be the TrioCode™ type and mixing of TrioCode™, Tri-Tran™ is not possible.

Deleting all stored transmitter codes from the receivers memory will allow you to choose either TrioCode™ or Tri-Tran™ transmitters again.

Coding Transmitter Buttons

Step 1. Navigating to "code transmitter" menu

1. Press NEXT to navigate to the Menu 1 (**Fig. 29**).
2. Press SET to enter code set procedure.

Step 2. Storing transmitter code

1. DCB-05 will prompt to press one of the transmitter's buttons.
2. Press the transmitter button you wish to use to operate the Gate Opener (e.g. button 1) (**Fig. 30**).
3. Press same transmitter button again as prompted by display (**Fig. 31**).

Step 3. Selecting function of the button

DCB-05 will now show the transmitter's record, with a cursor on the field for the button being coded (**Fig. 32**). Use UP/DOWN to select the function for the button.

Available functions:

VAC (Vacation Mode)	LGT (Courtesy Light)
STP (Stop)	OPN (Open)
CLS (Close)	SWP (Swipe)
PED (Pedestrian access)	OSC (Open/Stop/Close)
OFF (No action)	

Press SET to save the settings (**Fig. 33**) or EXIT to abort without saving. Press EXIT to return to the MAIN SCREEN and test the transmitter.

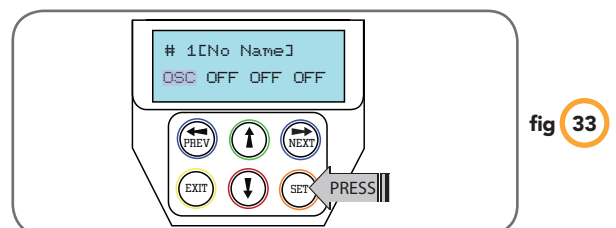
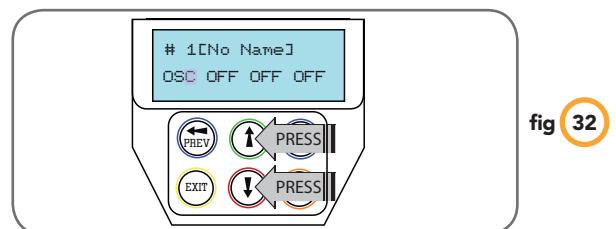
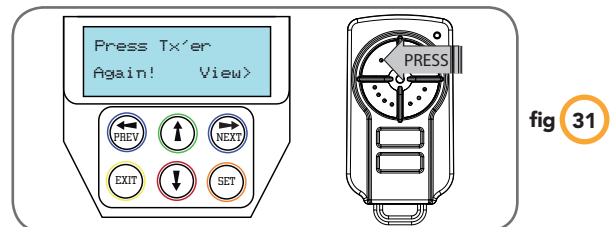
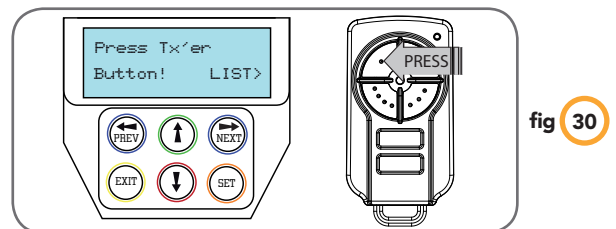
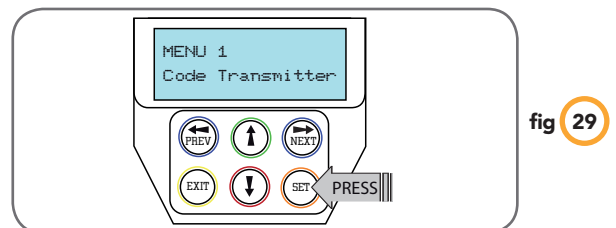
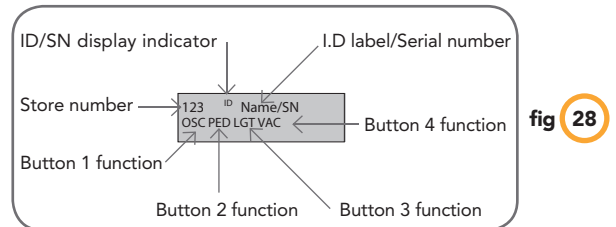



Standard Operation Modes

This section describes the standard operation of DCB-05 with the factory set default values.

Motor Control.

DCB-05 drives the motor in the appropriate direction as instructed by the control inputs. Once a cycle is started, the motor will continue to travel until:

1. DCB-05 is instructed to stop by a control input.
2. The motor's travel limit is reached.
3. The motor is obstructed, overloaded or stalls

When the control inputs instruct DCB-05 to change the motor direction, DCB-05 brakes the motor, waits for the motor to stop and then starts the motor in the other direction.

Motor Obstruction Detection

If a motor is obstructed while opening, the motor is stopped. If the motor is obstructed while closing, the motor is stopped and then reversed to the open position. Obstruction detection is achieved by monitoring the motor's current and comparing it to the "normal" current profile for the motor.

If the current of the motor rises above the "normal" MARGIN AMP setting, then the motor is said to be obstructed. In addition to the normal motor obstruction detection, motor overload and stall detection is provided to protect the gate opener and DCB-05.

Motor Speed Control

The motor's speed is controlled by varying the voltage applied to the motor. When the motor is started, the voltage is increased to the OPEN or CLOSE Speed Voltage parameter. When the limit switch of a drive unit is activated, the motor is slowed so as to come to a gentle stop.

Lock Release Output

The lock release output is configured to pulse for 0.5 seconds at the start of each cycle. The output is turned on at the same time the motors are started. The output is provided on OUTPUT1.

Courtesy Light

The courtesy light is normally used to illuminate the driveway. The light will be turned on each time the gate is activated (day or night) and automatically turned off 1 minute after the drive cycle has finished.

The light can also be activated and deactivated by pressing a transmitter button assigned the LGT function. The light output is provided on OUTPUT2 (requires additional light relay module RO-1).

Open / Stop / Close (Osc) Input

(Activated by OSC terminal with N/O switch or by transmitter button with OSC function assigned)

If the gate is stopped, the OSC input will cause the gate to move in the opposite direction to that last travelled. If the gate is moving, the OSC input will cause the gate to stop.

Pedestrian Access (Ped) Function

(Activated by PED terminal with N/O switch or by transmitter button with PED Function assigned)

The pedestrian access operation partly opens the gate to allow pedestrian access but prevent vehicle access. The position is automatically set to five (5) seconds from the fully closed position during setting of the travel limits, but can be manually adjusted.

Pedestrian access mode is entered when the input is activated and the gate is in the closed position. If the gate is not in the pedestrian access mode, the PED input will stop the gates if moving, or close the gates, if stopped.

While in pedestrian access mode, the pedestrian access position temporarily becomes the open limit for the gate leaf. The PED input then acts with an OSC type function. The pedestrian access mode is exited when the gate is closed or when another input is activated.



Standard Operation Modes

Close (Cls) Input

(Activated by CLS terminal with N/O switch, by transmitter button with CLS function assigned or by the DOWN button on the console.) Activating the CLS input will cause the gate to close. Holding the input active will prevent opening.

Swipe (Swp) Input

(Activated by SWP terminal with N/O switch or by transmitter button with SWP function assigned) Activating the the SWP input will cause the gate to be opened. If the terminal input is held, it will prevent the gate being closed. The swipe input also effects P.E TRIGGERED AUTO CLOSE.

Open (Opn) Input

(Activated by OPN terminal with N/O switch, by transmitter button with OPN function assigned or by console's UP button) Activating the OPN input will cause the gate to open. Holding the input will prevent closing.

Stop (Stp) Input

(Activated by STP terminal with N/O switch, by transmitter button with STP function assigned or by console's EXIT button) Activating the STP input while the gate is moving will cause the gate to be stopped. If the STP terminal is held, it will prevent the gate from being moved.

Photo Electric Safety Beam (PE) Input

When the PE input is active, the gate is prevented from being closed. If the PE input is triggered while the gate is closing, DCB-05 will stop the motors and then open the gate. The PE input has no effect while the gate is opening.

Vacation Mode

DCB-05 supports a Vacation mode where remote control access is disabled. The mode is activated by pressing a transmitter button with the VAC function assigned until the console displays that vacation mode is enabled (approx. 5 seconds).

When activated any transmitter button which is assigned VAC will be ignored. To turn the Vacation mode off, simply press a transmitter button with the VAC function assigned (only requires a brief activation). Vacation mode can also be turned on or off manually by editing the VACATION MODE parameter.

DCB-05 can be instructed, via the pedestrian control feature, to partly open and provide pedestrian access but prevent vehicle access. This is achieved by partly opening the motor 1 gate leaf. If dual motors are used, motor 2's gate leaf is held closed. The partly open position of motor 1's gate leaf is initially set to a position halfway between open and closed. This initial position can be adjusted by the installer to any position within the gates travel range by selecting a pedestrian access travel time (from closed). The setting is accessed from "MENU 10.4 Set Pedestrian". The time is adjustable in 1 second steps.

DCB-05 Adjustments

DCB-05's standard operation can be altered by editing various parameters. This section describes the parameters and the effect they have.

Menu 2. Current Trips

The obstruction margins are used to alter the sensitivity of the allowable variation between the "normal" speed profile and DCB-05 to obstructions. Increasing the value increases the force required to detect an obstruction.

Parameter (Limit Switch)	Min	Max	Default	Step	Unit	Menu No.
M1 MARGIN Sets obstruction detection margin for M1	0.0	5.0	0.7	0.1	AMPS	2
M2 MARGIN Sets obstruction detection margin for M2	0.0	5.0	0.7	0.1	AMPS	2
SETTLE TIME disable the obstruction detection in the start of the cycle	0.1	2.0	1.0	0.1	SEC	2





DCB-05 Adjustments (Cont.)

Menu 3. Auto-Close times

The Auto-Close modes automatically closes the gate after it has been operated. To implement this, DCB-05 starts a timer once the gate has reached its desired open position. The timer then counts down and when it expires, the DCB-05 starts to close the gate. Details of the four Auto-Close modes are outlined below. Automatic Technology strongly recommend using a PE Beam for added safety.

Standard Auto-Close

This mode is selected by entering a non-zero time for the **STD Auto-Close** parameter.

When selected, the gate will Auto-Close after being fully opened (except when the gate has reversed to the open position after a motor obstruction or overload).

Countdown is suspended by: PE, OPN or SWP input being active. The countdown is aborted if the STP input is activated.

If the gate is already open and the OPN or the SWP input is activated, then the countdown will start.

PE Triggered Auto-Close

This mode is selected by entering a non-zero time for the **"PE Auto-Close"** parameter.

This mode is used to auto-close the gate but only after a vehicle have passed through the gateway and triggered the PE input. The swipe input can be used to clear the PE triggered status so that the PE input must be activated again before the countdown will start.

As with the other PE modes, the STP input will abort countdown and the OPN and SWP inputs will restart the countdown if the gate is OPEN.

Pedestrian Access Auto-Close

This mode is selected by entering a non-zero time for the **"Ped'n A/C"** parameter.

When selected, the gate will Auto-Close after being opened for pedestrian access unless it was following a reverse from an obstruction.

PE Triggered Pedestrian Auto-Close

This mode is selected by entering a non-zero time for the **"PE Ped'n A/C"** parameter.

This mode is the same as the PE triggered auto-close mode, but it only operates during pedestrian access. As the SWP input is not available during pedestrian access, the PED input can be configured to act in a SWP mode by setting the **"PED I/P = PED SWIPE MODE"** parameter to **ON**.

Auto-Close After Obstruction

Two parameters are provided to enable the Auto-Close feature to be activated after obstructions. Normally the Auto-Close feature is not enabled after obstructions for safety reasons. PE beams must be used for these features to be activated.

Parameter	Min	Max	Default	Step	Unit	Menu No.
STD AUTO-CLOSE TIME Sets and enables the standard Auto-Close time	0.0	300.0	0.0	1.0	Sec	3
PE AUTO-CLOSE TIME Sets and enables the PE triggered Auto-Close time	0.0	60.0	0.0	1.0	Sec	3
PEDESTRIAN AUTO-CLOSE TIME Sets and enables the Pedestrian Auto-Close time	0.0	60.0	0.0	1.0	Sec	3
PE PEDESTRIAN AUTO-CLOSE TIME Sets and enables the PE Pedestrian Auto-Close time	0.0	60.0	0.0	1.0	Sec	3
AUTO-CLOSE AFTER CLOSE OBSTRUCTION Enables Auto-Close feature after close obstructions	Off	On	Off			3
AUTO-CLOSE AFTER OPEN OBSTRUCTION Enables Auto-Close feature after open obstructions	Off	On	Off			3
AUTO-CLOSE AFTER POWERUP Enables Auto-Close feature after powerup	Off	On	Off			3





DCB-05 Adjustments (Cont.)

Menu 4. Lock times

DCB-05's lock function can be programmed for both hold and pulse operation. The lock output can also be programmed to activate prior to the motor starting. The open and close cycle actions can be programmed differently. The lock can be either OUTPUT1 or OUTPUT2 (see OPERATING MODES).

Parameter	Min	Max	Default	Step	Unit	Menu No.
OPEN LOCK TIME Set the time the lock is activated for on open cycles	0.0	Hold	0.5	0.1	Sec	4
CLOSE LOCK TIME Set the time the lock is activated for on close cycles	0.0	Hold	0.5	0.1	Sec	4
PRE-OPEN LOCK TIME Time the lock is activated for prior to opening	0.0	25.5	0.0	0.1	Sec	4
PRE-CLOSE LOCK TIME Time the lock is activated for prior to closing	0.0	25.5	0.0	0.1	Sec	4

Menu 5. Light times

DCB-05's light function can be programmed to operate a courtesy light or a warning light. The time the light stays on for after a cycle is adjustable.

The light can also be activated prior to the gate moving so that a warning can be given of the pending movement. Note the light output can be selected to be either OUTPUT1 or OUTPUT2. The parameters are shown below.

Parameter	Min	Max	Default	Step	Unit	Menu No.
ON AFTER CYCLE LIGHT TIME Time light remains on for after a cycle	0	255	60	1	Sec	5
ON BEFORE OPEN CYCLE LIGHT TIME Minimum time light is activated for prior to opening	0	255	0	1	Sec	5
ON BEFORE CLOSE CYCLE LIGHT TIME Minimum time light is activated for prior to closing	0	255	0	1	Sec	5

Menu 6. Motor settings

The motor settings adjust various aspects of the gate travel. When a single gate installation is used, the SYNC DELAY TIMES and M2 settings are ignored. The default value for the CLOSE SYNC DELAY time is automatically calculated for LIMIT SWITCH/AMP TRAVEL installations.

The value calculated is selected so that the delay between M2 and M1 reaching the close position is equal to the OPEN SYNC DELAY TIME. The MAX OVERRUN TIME is set to 0 for TIMED TRAVEL installations.





DCB-05 Adjustments (Cont.)

Parameter	Min	Max	Default	Step	Unit	Menu No.
CLOSE SYNC DELAY TIME Time delay between M2 and M1 closing	0.0	25.5	2.0	0.1	SEC	6.1
OPEN SYNC DELAY TIME Time delay between M1 and M2 opening	0.0	25.5	2.0	0.1	SEC	6.2
OPEN SPEED VOLTS Voltage applied to motors when opening	12	24	22	1	VOLTS	6.3
CLOSE SPEED VOLTS Voltage applied to motors when closing	12	24	20	1	VOLTS	6.4
SLOW SPEED VOLTS Voltage applied to motors when slowing down	6	24	8	1	VOLTS	6.5
SLOW TIME The time between slow down and end of cycle	0.1	10.0	3.0	0.1	SEC	6.6
HOMING / SETUP SPEED VOLTS Voltage applied to motors when setting up the travel limits	12	24	Norm	1	Volts	6.7
STOP PAUSE TIME Pause time used between motor direction changes	0.0	2.0	0.2	0.1	SEC	6.8
M1 NORMAL OPEN TIME Normal open time for motor 1	0.0	60.0	0.0	0.1	SEC	6.9
M1 NORMAL CLOSE TIME Normal close time for motor 1	0.0	60.0	0.0	0.1	SEC	6.10
M2 NORMAL OPEN TIME Normal open time for motor 2	0.0	60.0	0.0	0.1	SEC	6.11
M2 NORMAL CLOSE TIME Normal close time for motor 2	0.0	60.0	0.0	0.1	SEC	6.12
MAX OVERRUN TIME Extra time allowed for cycle to complete (beyond normal cycle time)	0	60	5	1		6.13

Menu 7. Operating modes

PE input response mode

The PE input can be configured to respond in one of three modes.

Open and close cycles stop

In this mode, all cycles are prevented from being completed or initiated when the PE input is active.

Close cycles stop

In this mode, the PE input has no effect when opening but will stop the gate when closing.

Reverses close cycles

In this mode, the PE input has no effect when opening but will cause the gate to reverse if activated when closing.

PED input function

The PED input can be configured to a SWIPE type input for pedestrian access. This provides full functionality with the PE Triggered Pedestrian Auto-Close function.

Remote code

DCB-05 supports the Remote Code Set feature. This parameter can be used to disable the feature for security or transmitter management reasons.





DCB-05 Adjustments (Cont.)

Vacation mode

Vacation mode can be turned on or off using this parameter.

Battery/solar mode

Solar mode can be turned on or off using this parameter.

Open input polarity

The OPN input is normally configured for N/C operation. This parameter allows its operation to be changed to N/O.

Password protection

The password feature enables all parameters and configuration settings to be protected unless a password is entered. When this feature is turned on the user is requested to enter the desired password to be used. The password protection feature has a time-out that expires after 60 seconds of inactivity. Alternately the user may log out manually by pressing exit when the main screen is displayed.

Parameter	Min	Max	Default	Menu No.
PE INPUT RESPONSE MODE Sets the PE response mode. Options are OPEN and CLOSE cycles stop, Close cycles stop or Close cycle reverse	NOT USED		CLS to reverse	7.1
PED INPUT = SWIPE MODE Selects PED input functions as pedestrian access swipe input	Off	On	Off	7.2
REMOTE CODE ENABLED Selects remote transmitter coding function	Off	On	On	7.3
VACATION MODE Selects vacation mode - disables remote control	Off	On	Off	7.4
BATTERY/SOLAR MODE Selects Battery Backup/Solar operation	Off	On	On	7.5
PASSWORD Selects password protection for all changes	Off	On	Off	7.6
TX # GROUPING Selects transmitter number group display format	Off		Off	7.7
OPN INPUT N/C OPERATION Selects operating polarity of OPN input	Off	On	Off	7.8
STP INPUT N/C OPERATION Selects operating polarity of STP input	Off		Off	7.9
OUTPUTS 1&2 Selects function of OUTPUT1 and OUTPUT2	OUTPUT1= LOCK OUTPUT2= LIGHT	OUTPUT1= LIGHT OUTPUT2= LOCK	OUTPUT1= LOCK OUTPUT2= LIGHT	7.10
OPN INPUT = 2ND PE Open input acts as 2nd PE input				7.11
FAULT AUTO RESET				7.12





Diagnostic Tools

fig 34

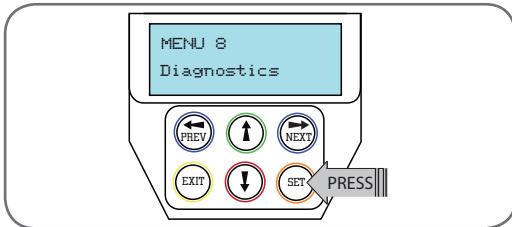

DCB-05 provides several diagnostic tools from within the diagnostics menu (Menu 8). This section details the function of each tool.

Navigating to diagnostics menu

1. Press PREV to navigate to Menu 8.
2. Press SET to display menu of available functions (**Fig. 34**).
3. Press PREV or NEXT to cycle through diagnostic tool.
4. Press SET to select.

fig 35

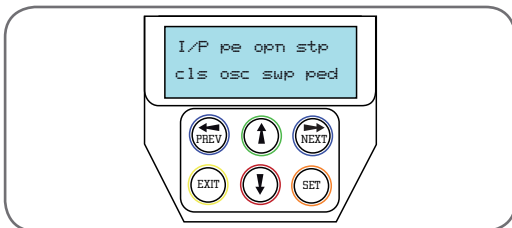

Menu 8.1 Test Inputs

This tool is used to view the state of the control inputs. When selected, a screen is displayed (**Fig. 35**) which indicates the state of each input. If the name of the input is in uppercase, then the input is active. Conversely if the input is in lower case, then the input is inactive.

For normal operation all inputs should be inactive. When finished press EXIT. The example shows the status as OSC input is active.

fig 36

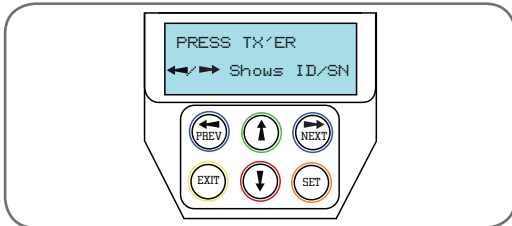

Menu 8.2 Test Tx'ers

This tool is used to test receiver/transmitter functionality. When selected, a screen is displayed which prompts for a transmitter button to be pressed (**Fig. 36**) and whether ID or serial numbers are to be displayed.

fig 37

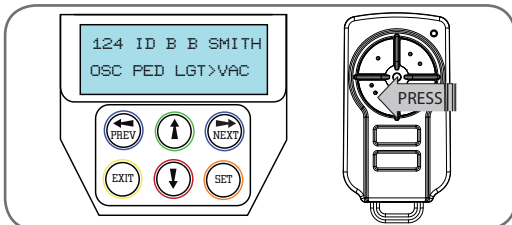

DCB-05 will then beep each time a transmission is received. If the transmitter button is stored in the DCB-05's memory and has a function assigned to it, a second screen will be displayed that shows the transmitter details along with the button pressed (**Fig. 37**).

The example shows the case when transmitter number 12 is activated by button 4. Note ID is selected for display.

fig 38

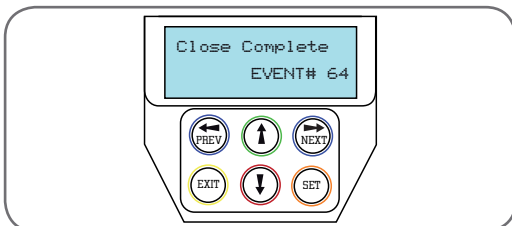

Menu 8.3 Display History

DCB-05 keeps a record of the last 64 events that have taken place. The events include the type of drive cycles executed, obstruction detection, various faults, power failures etc.

When this tool is selected, the screen displays the last event that occurred (**Fig. 38**). Press NEXT or PREV to view each event. The "EVENT#" field shows the sequence of the events, with (1) being the first and (64) being the last.

The example shows that the last event was a close cycle which succeeded in closing the gate. When finished viewing the events, press EXIT.

fig 39

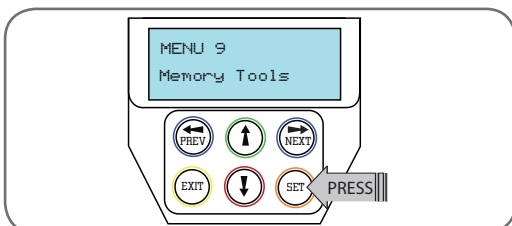

Menu 8.4 Memory Usage

This tool displays the number of transmitter store location used and the number free (**Fig. 39**).





Menu 8.5 Service Counter

DCB-05 provides a periodic service counter which can be set to expire after a number of drive cycles.

When expired, DCB-05 will beep at the beginning of each drive cycle and a message will be displayed on the MAIN SCREEN (**Fig. 40**). This tool displays the current value of the service counter and allows the user to set its value using the normal parameter editing techniques (See PARAMETER VIEWING AND EDITING).

If the service counter is not to be used it can be set to the maximum number (60,000).

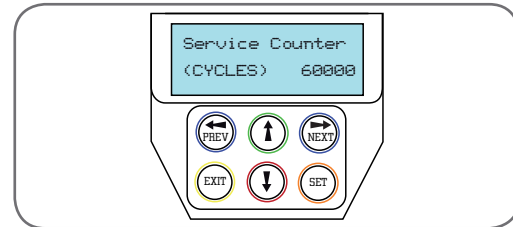

fig 40

Menu 8.6 Counters

The opener keeps a count of number of times a particular event occurs. The list of event counters kept is shown below.

When this tool is selected, the first event counter is shown (**Fig. 41**). Press NEXT or PREV to step through the list.

The example below shows the OPEN CYCLE event counter with a value of 1234. When finished viewing press EXIT.

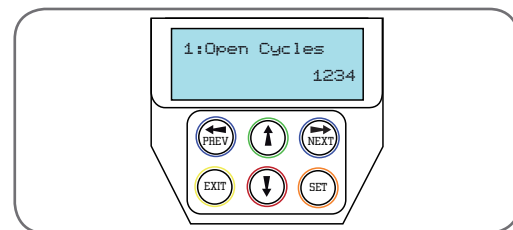

fig 41

1. Open Cycles
2. Close Cycles
3. Ped Cycles
4. Warranty cycles
5. Setup Limits
6. Overlaps
7. M1 Open Obstructions
8. M2 Open Obstructions
9. M1 Close Obstructions
10. M2 Close Obstructions
11. M1 Open Overloads
12. M2 Open Overloads
13. M1 Close Overloads
14. M2 Close Overloads
15. M1 Drive Faults
16. M2 Drive Faults
17. M1 Volt Faults
18. M2 Volt Faults
19. M1 Amp Faults
20. M2 Amp Faults
21. Supply Hi Fault
22. Supply Low Fault
23. M1 Amp Trip Fault
24. M2 Amp Trip Fault
25. Three Wire Limits Fault





Memory Tools

fig 42

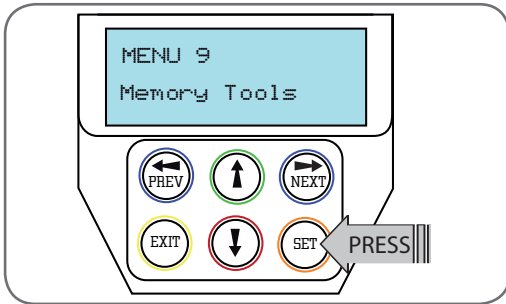

The Memory Tools accessed from within Menu 9 are used to backup, restore or clear the controller. Once selected, the PREV or NEXT buttons can be used to view the Memory Tool options. To execute the displayed option simply press SET (Fig. 42).

Menu 9.1 Clr Control

This option will clear the gate control memory and reload the factory set defaults for parameters such as the lock time, light time, Auto-Close times etc. It will also clear the travel limits.

Menu 9.2 Clr Tx'ers

This option will clear the transmitter storage memory.

Setting Pedestrian Position

fig 43

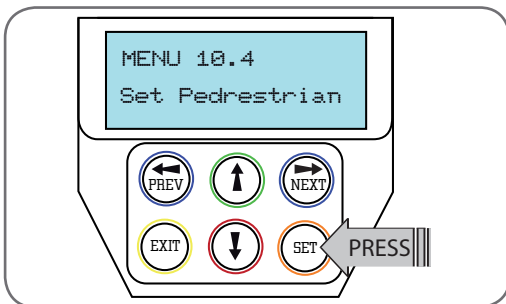

DCB-05 can be instructed, via its pedestrian control feature, to partly open and provide pedestrian access but prevent vehicle access. This is achieved by partly opening the motor 1 gate leaf.

If dual motors are used, motor 2's gate leaf is held closed. The partly open position of motor 1's gate leaf is initially set to five (5) seconds from fully closed position. This initial position can be adjusted by the installer to any position within the gates travel range by selecting a pedestrian access travel time (from closed). The setting is accessed from "MENU 10.4 Set Pedestrian" (Fig. 43).

The time is adjustable in 1 second steps.

fig 44

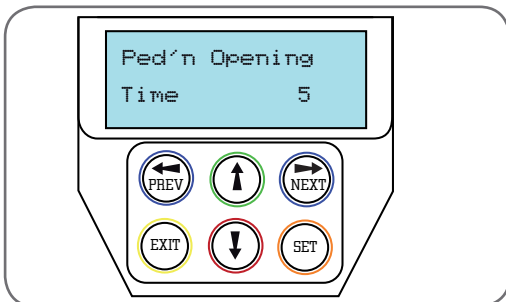

Step 1. Navigating to "set pedestrian menu"

1. Press PREV to navigate to Menu 10
2. Press SET - MENU 10.1 is displayed.
3. Press NEXT to go to MENU 10.4.
4. Press SET to enter Set Pedestrian procedure (Fig. 44).

Step 2. Setting pedestrian position

1. Press OPEN or CLOSE to adjust pedestrian drive time.
2. Press SET to record position
3. Press transmitter coded for pedestrian function or push button wired into pedestrian input to test.





Accessories Installation

Photo Electric (PE) Beams

A photo electric (PE) Beams extends across the gate opening. This photo electric (PE) Beams is designed to detect an obstruction while the gate is closing and to send a signal to the gate opener to reverse or stop the gate movement.

Fitting Photo Electric (PE) Beams

- Attach the mounting bracket (4) to adjustment bracket (3) with the pan head screw (6) (supplied) (Fig. 45).
- Attach the PE 2000TS bracket (2) to PE beam transmitter (IR-200TS-TX) with four taprite screws (m3x5) and attach the other side to adjustment bracket (3) with the pan head screw (6) (supplied).
- Repeat steps a and b to assemble the PE Beam receiver (IR-200TS-RX).

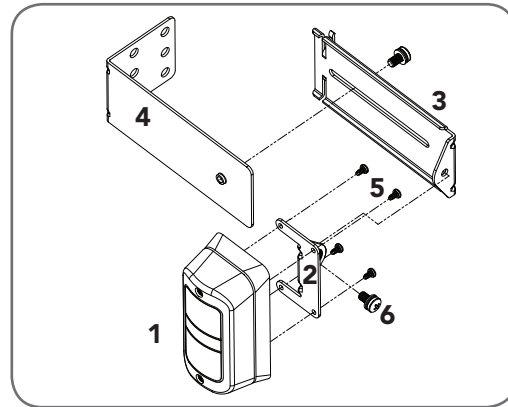

fig 45

Locate the Photo Electric (PE) Beams in a strategic location in the gateway. Automatic Technology recommend that the sensor is placed 150 mm above the floor level. Connect as per the wiring diagram (Fig. 47). Use 5.6 kilo ohm resistor with the colour code green, blue, red and gold on the PE Beams receiver between the V- and NC terminals as shown in (Fig. 47).

Alignment

- Power up the PE Beams. The green LED on the transmitter and red LED on the receiver should turn ON to indicate power is present.
- If the receiver is connected to power and the red LED is on while the green LED is on, the transmitter and receiver are not aligned.
- Make horizontal and/or vertical (Fig. 46) adjustment on the transmitter and/or receiver until the red LED turns off on the receiver, indicating alignment.

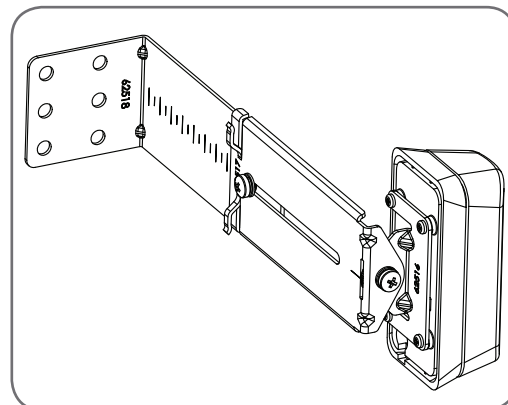

fig 46



NOTE: The height of the beam installation must be chosen in such a manner that it suits the application and environmental conditions and provides maximum safety protection.



WARNING: When using PE Beams, the gateway must be clear of all obstructions and persons at all times. The location of the beams and manner in which it is installed might not give safety protection at all times. Check to make sure that the height of the beam and type used give maximum protection possible.



WARNING: Install the PE Beams as per diagram in Fig. 47. **Tampering** with the PE Beams could result in serious personal injury and/or property damage and will void the warranty.

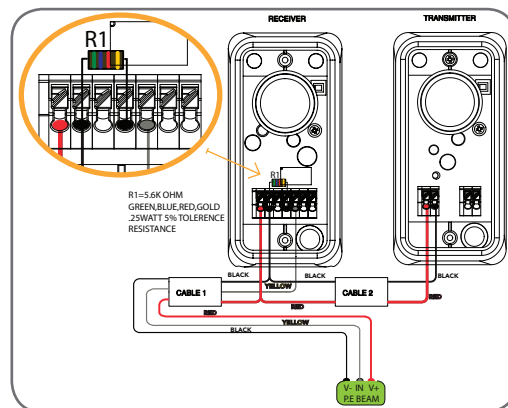

fig 47





Accessories Installation

fig 48

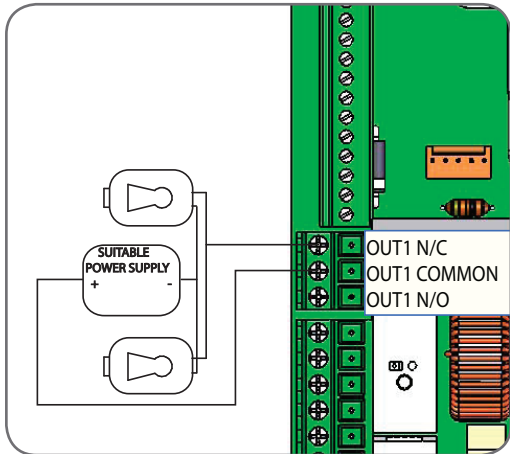

Wiring Output1 And Output2

Outputs 1 and 2 are used to control a lock and a light. Which output is to control which function and the way it is controlled, is programmable.

If using these outputs make sure that the functions are configured for correct operation prior to setting the travel limits.

OUTPUT1 is a relay output with high current capability. OUTPUT2 is used to activate an optional external relay module (RO-1) which in turn is used to switch the load.

Fitting solenoid or magnetic locks

Install the lock mechanism on the gate as per the manufacturers instructions. The wiring diagram on the left is a representation of a typical lock with a bias for normally closed contact (**Fig. 48**).

fig 49

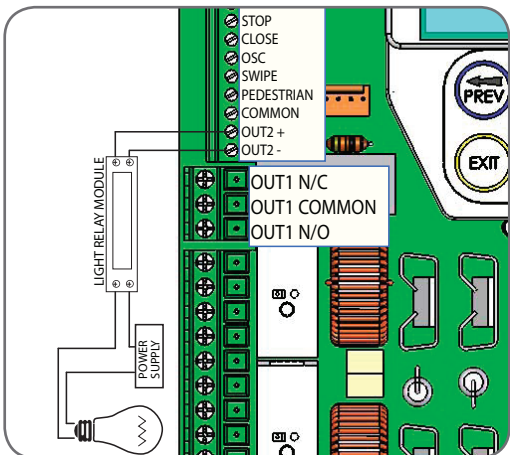

Fitting courtesy lights

An AC or DC courtesy light can be activated via an output on the gate opener control board. Connect the light as per the diagram on the left (**Fig. 49**).



WARNING: A qualified electrician must perform the installation where 240V AC power is used.

Wiring Control Inputs

The console switch inputs may be used for operating the gate via any device that provides a switch contact output.

AUX, OPN, STP, CLS, SWP, PED requires normally open contact switches (**Fig. 50**). OPN and STP inputs can be configured to take normally close contact switches.

fig 50

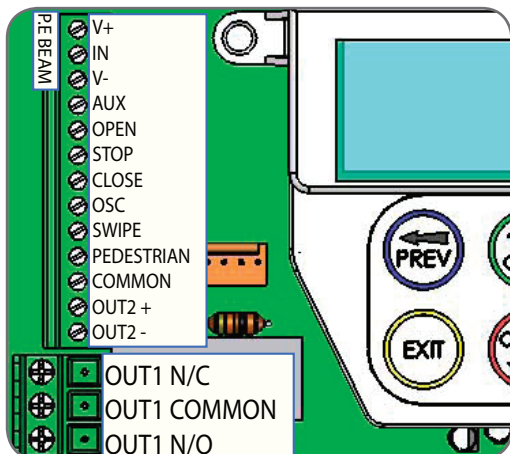



Battery Backup Installation

Connect the Battery Backup Kit

1. Disconnect power to the DCB-05.
2. Secure the SBY-3 Charger Board in the control box with sticky pads (supplied with the battery charger kit part number # 90188).
3. Connect the SBY-3 charger board to battery box and to DCB-05 as shown (**Fig. 51**).
4. Reconnect power.
5. From menu 7.9 select the "battery enabled option"

Testing Battery Backup

1. Press transmitter to test the gate opener.
2. Whilst gate is in motion, disconnect mains power. The gate should continue to operate as normal.

NOTE: Wait for the gate to complete its travel.

3. Press the transmitter to activate the gate.
4. Whilst gate is in motion re-connect power. The gate should complete the cycle as normal.

Troubleshooting

If gate stops or moves very slowly under battery power, the batteries may be weak or have no charge. Connect mains power and allow the batteries to charge. This may take 24 - 48 hours to reach maximum charge capacity.

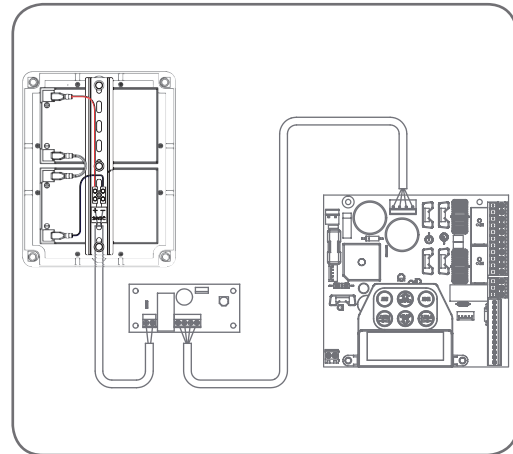

fig 51





Troubleshooting guide

Gate does not open or close	<p>Check that power is still available at mains power point. Check that Control Box is plugged into mains power. Check that motor is engaged for automatic operation. Check all wiring from motor and microswitches to the control board are sound.</p>
Gate reverses while closing or stops while opening	<p>Check obstruction overload sensitivity adjustment. Check for obstructions. Disengage the drive unit to manual and check the gate is in good working order. If a P.E. beam is fitted, ensure it is clear of obstructions or dirt on the lens.</p>
Transmitter not functioning	<p>New transmitters must be coded to the receiver. Check/change the battery in the transmitter (LED flashes to indicate low battery). Having the antenna behind a structure (gate or fence) or not in line of sight may reduce optimal range/reception. Interference from external/outside sources such as baby monitors, or radio transmitter etc. The best solution is to remove the source causing the interference.</p>
Gate and/or opener requires service	<p>Contact the installer of the opener or local ATA dealer for service. They will be able to inspect, service, adjust or repair the gate and opener as necessary.</p>



Specification

Drive unit	
Motor Voltage	24V DC
Maximum Pulling Force	200N (20Kg)
Drive Arm Rotation Speed	Approx. 8°/sec
Dimensions	135W x 290H x 230D (mm)
Weight	13Kg (incl. arms)
Max Weight Of The Gate	250 kg ¹

Control Box	
Protection rating	24V DC
24VDC accessory output	24VDC (unfiltered) 3Amp maximum
Secondary voltage:	24V AC 150 VA
Receiver type:	433.92 MHz TrioCode™ or Tri-Tran™ 2
Receiver code storage capacity:	511 x 4 Button Transmitter Codes
Transmitter frequency:	UHF Multi-frequency FM Transmitter
Coding type:	Hopping Code
Code generation:	Non-linear encryption algorithm
Transmitter battery:	CR2032

Note:

1. The maximum weight gate that the opener can be installed on 250Kg. The gate must be well balanced. A person of limited strength should be able to move the gate manually with very little effort (15Kg force max.) in case of an emergency.
2. The first memory location sets the type of transmitters which can be stored into the receivers memory. It either can be ATA TrioCode™ or B&D Tri-Tran™ transmitters.





Spare Parts List

ITEM NO.	DESCRIPTION	ORDER CODE	ITEM NO.	DESCRIPTION	ORDER CODE
1	GEAR 2 SUB-ASSY (130246)	60152	38	O RING Ø 30MM	64550
2	SUPPORT 1 (10010070)	64440	39	CAP HEAD SCREW M6x16	10020
3	SHAFT 1 (10010070)	64521	40	SPRING WASHER LD 6	10880
4	SHAFT 2 (13041)	64521	41	FLAT WASHER LD 6	11040
5	SPACER 1 (13041)	64520	42	COVER ASSY SGC-1	60151
6	SLEEVE 15.3 (13180)	64370	43	COVER SGC-1	64550
7	SLEEVE 30.7 (13190)	64380	44	COMMON LOCK CAP	13550
8	BUSHING LD 22 (13070)	64490	45	LABEL SWING GATE	64620
9	SUB-ASSY 2 (10010080)	64450	46	LOCKS - KEY	14300
10	SUB-ASSY 1 (10010080)	64450	47	THRUST WASHER MTA-815	10780
11	KEY 16.4 (10010120)	64440	48	SNAP PIN SUS 30120 S/STEEL	64602
12	RETAINING RING STW 22	10740	49	SLAVE ARM	64812
13	GEAR 2825 (130322)	64480	50	WASHER PL ASTIC	64816
14	CAM (13060)	11000	51	SHOULDER SCREW 1815	10810
15	FLAT WASHER LD 12	10950	52	HEX HEAD SCREW M10x20	10065
16	FLAT WASHER LD 12	10950	53	SPRING WASHER LD 10	10840
17	MICROSWITCH 27P/PPY/WH/15H/04 C	68271	54	FLAT WASHER LD 10	11010
18	TERMINAL STRIP 328 HDS ØS FOS	65420	55	GATE MOUNTING BRACKET	64582
19	WIRE ASSY NO. 1 (YELLOW)	12070	56	HELICAL GEAR WASHPAK	10400
20	WIRE ASSY NO. 2 (RED)	12080			
21	WIRE ASSY NO. 3 (ORANGE)	12090			
22	WIRE ASSY NO. 4 (GREEN)	12100			
23	WIRE ASSY NO. 5 (BLUE)	12110			
24	WIRE ASSY NO. 6 (PURPLE)	12120			
25	PAN. HEAD SCREW M3x12	10460			
26	PAN. HEAD SCREW M3x12	10460			
27	PAN. HEAD SCREW M3x16	10350			
28	HEX NUT M8	10870			
29	SPRING WASHER LD 8	10950			
30	INTERNAL LOCK WASHER LD 3	11150			
31	DRIVE ASSY 6 SGC-1	60351			
32	DRIVE ASSY 6 SGC-1	60351			
33	SUPPORT MOTOR	60369			
34	LOCK PIN	64420			
35	GEAR 1	64350			
36	GEAR 1	64460			
37	E-CIRCLIP D1500 040	10880			

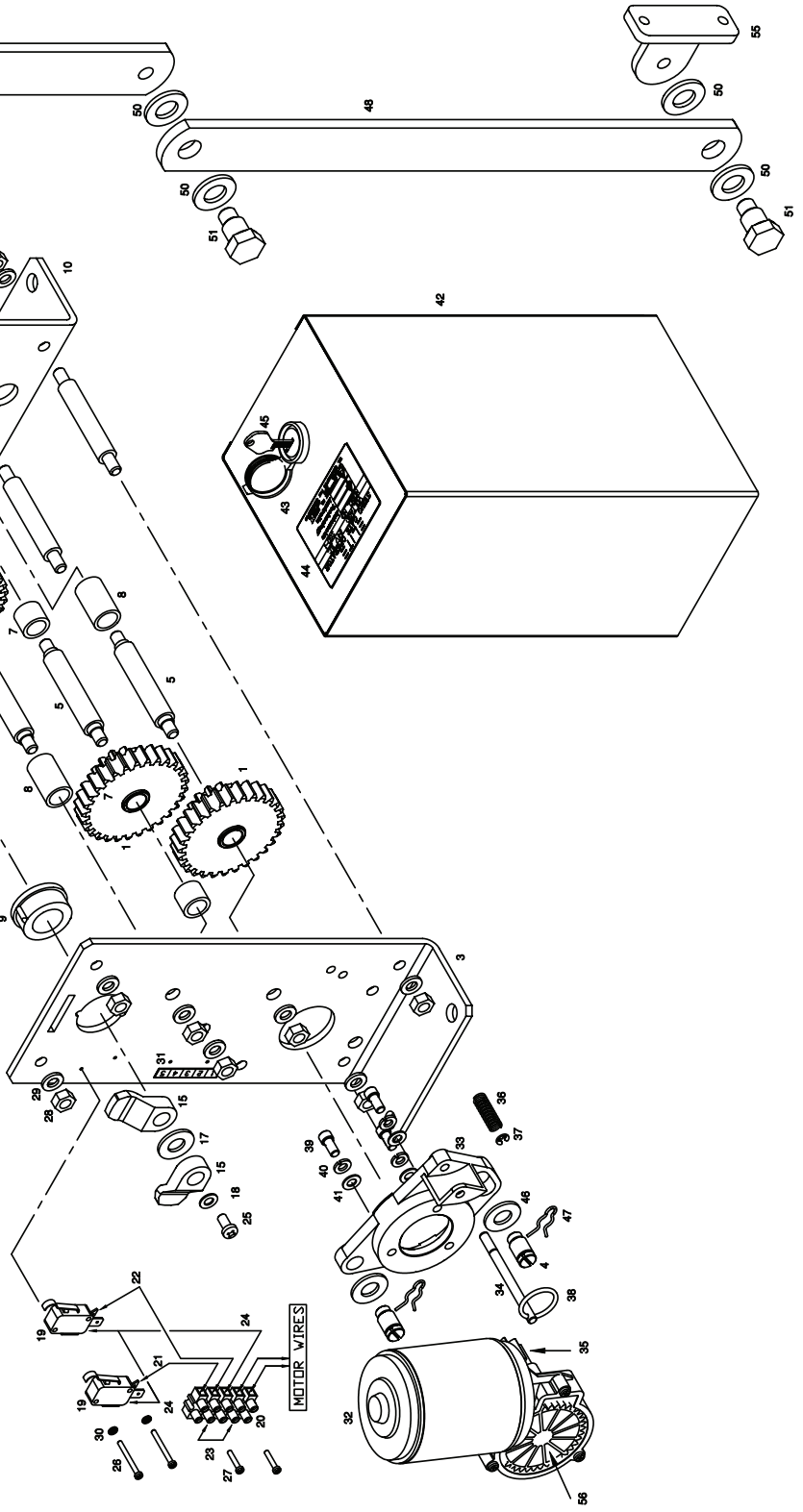



Notes And Record

Purchased from: _____ Phone: _____

Installed by: _____ Date: _____

Serial No: _____





Warranty

1. This warranty is an addition to any non-excludable conditions or warranties that are implied into this contract by relevant statute, including the Trade Practices Act 1974 (Cth).
2. Subject to all of the matters set out below, Automatic Technology Australia Pty Ltd ("ATA") warrants:
 - (a) swing and sliding gate opener drive units for twelve (12) months or 2500 cycles, whichever occurs first;
 - (b) roll-up and overhead door opener drive units for twenty four (24) months or 5000 cycles, whichever occurs first; and
 - (c) all components and accessories for twelve (12) months, from the date of purchase (specified in the sales docket receipt) as free of any defects in material and workmanship.
3. This warranty applies only where the purchaser:
 - (a) immediately notifies ATA or the retailer of the alleged defect;
 - (b) returns the product to the retailer; and
 - (c) presents the relevant sales docket and this warranty document to the retailer to confirm the date of purchase.
4. Except for this warranty, ATA gives no warranties of any kind whatsoever (whether express or implied), in relation to the product, and all warranties of whatsoever kind relating to the product are, to the extent permissible by statute, hereby excluded.
5. To the extent permissible by statute, ATA disclaims any liability of whatsoever nature in respect of any claim or demand for loss or damage which arises out of:
 - a) accidental damage to or normal wear and tear to the product or to the product's components;
 - b) any cost relating to damage resulting from wear and tear;
 - c) blown fuses, loss or damage caused by electrical surges, power surges or power spikes;
 - d) loss or damage due to theft, fire, flood, rain, water, lightning, storms or any other acts of God;
 - e) maximum continuous operating time exceeding one (1) minute in ten (10);
 - f) maximum operating force exceeding 15kg (150N) when moving the door or gate manually to the open or closed position;
 - g) door surface area and/or weight exceeding 15m² and 100kg respectively;
 - h) residential gate weight exceeding 400kg;
 - i) door or gate not in safe and correct working order and condition;
 - j) evidence of unauthorised repairs;
 - k) any cost relating to damage caused by misuse, negligence or failure to maintain the equipment in a proper working order as per clauses (d) through (i);
 - l) installation, adjustment or use which is not in accordance with the instructions set out in installation instruction manual;
 - m) attempted or complete modification or repairs to the product carried out by a person who is not authorised or has not been trained by ATA to carry out such modification or repairs;
 - n) faulty or unsuitable wiring of structure to which the product is fixed or connected;
 - o) radio (including citizen band transmission) or any electrical interference;
 - p) damage caused by insects;
 - q) loss or damage to any property whatsoever or any loss or expense whatsoever resulting or arising there from or any consequential loss;
 - r) any cost or expense arising due to manufacturer recall of any product;
 - s) any cost or expense due to negligence of the approved service provider;
 - t) installation of a residential garage door or gate opener in a commercial or industrial situation or a non-single residential dwelling.
6. ATA's liability under this warranty is limited, at ATA's absolute option, to replacing or repairing the product which ATA, in its unfettered opinion, considers to be defective either in material and/or workmanship or to credit the dealer with the price at which the product was purchased by the dealer.
7. This warranty does not extend to cover labour for installation.
8. This warranty is limited to Return-to-Base (RTB) repair and does not cover labour for on-site attendance.
9. This warranty is void if the Product is not returned to the manufacturer in original or suitably secure packaging.
10. This warranty is only applicable for repairs to the product carried out within Australia.
11. This warranty does not cover consumable items including globes, batteries and fuses.
12. This warranty is not transferable.
13. Where the Product is retailed by any person other than ATA, except for the warranty set out above, such person has no authority from ATA to give any warranty or guarantee on ATA's behalf in addition to the warranty set out above.

NOTES:

1. One (1) cycle = one (1) open and one (1) close action of the door or gate.
2. This warranty is to be read in conjunction with the owner's copy of the installation instruction manual.







© October 2009 Automatic Technology (Australia) Pty Ltd. All rights reserved. Elite® is registered and TrioCode™ is the trademark of Automatic Technology (Australia) Pty Ltd. Tri-Tran™ is a trademark of B&D Doors and openers. No part of this document may be reproduced without prior permission. In an ongoing commitment to product quality we reserve the right to change specification without notice. E&OE.

automatic
TECHNOLOGY

smart | simple | secure

an alesco company

Automatic Technology (Australia) Pty Ltd

ABN 11 007 125 368

6-8 Fiveways Boulevard
Keysborough, Victoria, 3173, Australia

P 1300 133 944

+61 3 97910200 (International Enquiries Only)

E sales@ata-aust.com.au

www.ata-aust.com.au